

Installation Precautions:

1. Please read through the Instructions before installation.
2. Fixtures are designed for use on W2 three phase track systems. They may also be used on other manufacturer's brand of compatibility track. Matching track parameters: Input voltage: AC 220-240V, Maximum current: 16A.
3. **The fixture has 0-10V dimming function. To prevent the fire of the track system, it is strictly prohibited to connect the track dimming wire to the mains.**
4. The product should be installed by a professional electrician.
5. Suit for dry location, do not install in damp or wet locations.
6. The fixtures need to undergo compatibility testing with the dimming system in advance.
7. Please keep this Instruction properly for future reference.

Attention: To prevent electric shock and damage to the fixture, please turn off the power before installing, maintaining, or replacing accessories. It is not allowed to install with electricity.

Schematic diagram of track electrification:

The lamp has dimming function of 0-10V. Please ensure that the wiring of the rail power inlet is consistent with the diagram below:

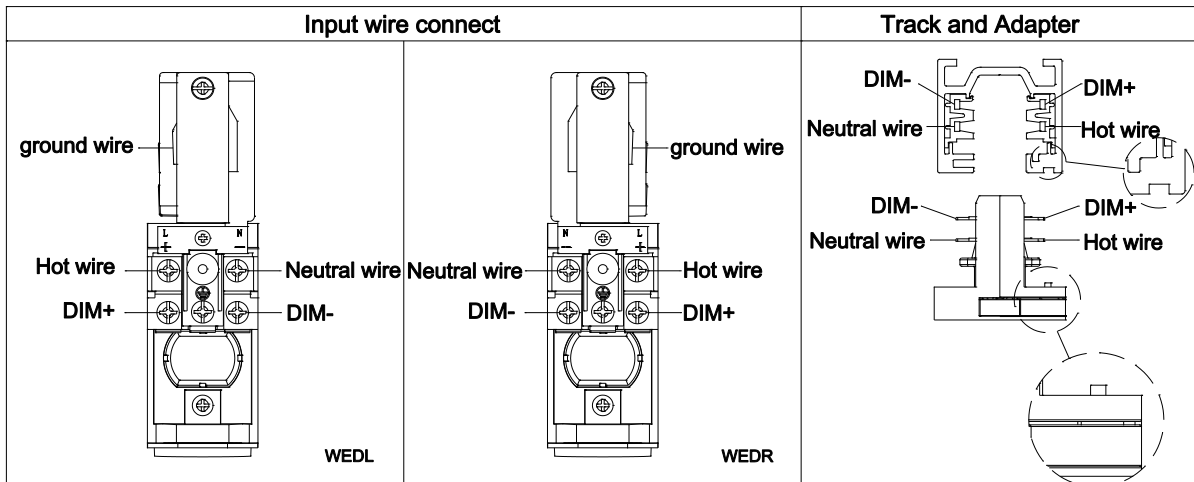

Installing adapter on track:

1. Before installation, ensure that the conductive sheet is in a recycled state (completely hidden inside the adapter), and ensure that the adapter convexity is on the same side as the track groove, as shown in the following figure:
2. After the adapter is inserted into the track, forcefully pull the "conductive lever" clockwise to the buckle for conduction (with a noticeable "click" sound).

Note: Removing the adapter is the opposite of installing the adapter program.

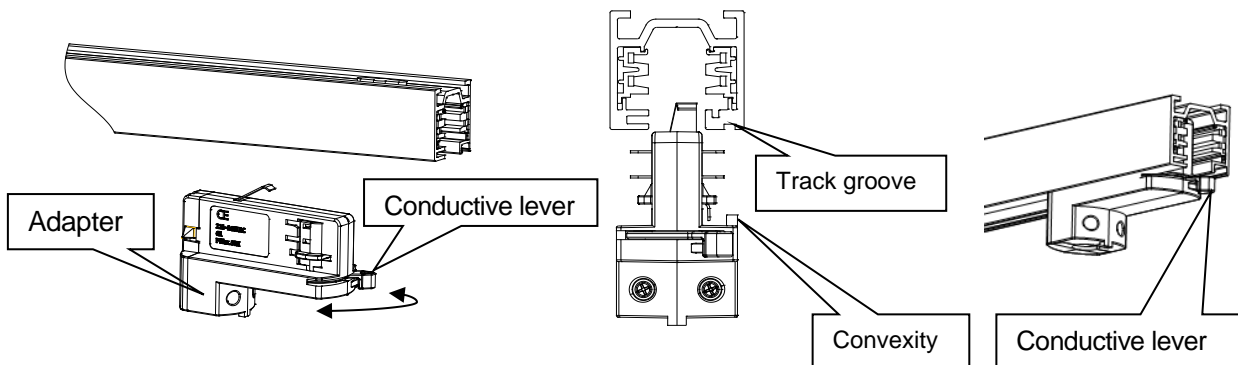

Lamp size (mm):

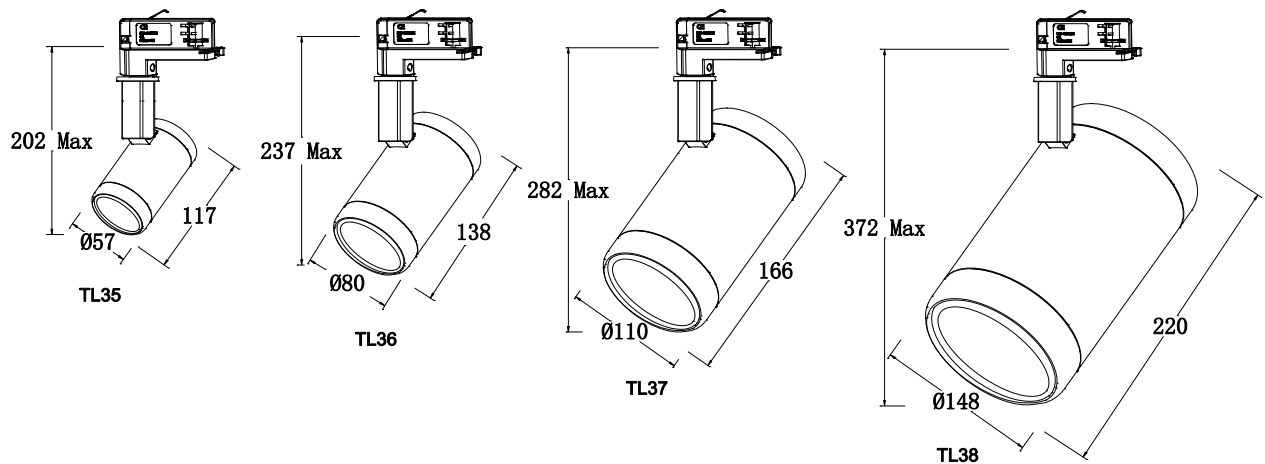

Fixture adjustment:

1. After install, the lamp body can be rotated vertically 90 ° and horizontally 365 °.
2. The lamp has knob or 0-10V dimming function.
3. The lamp has DALI dimming function.

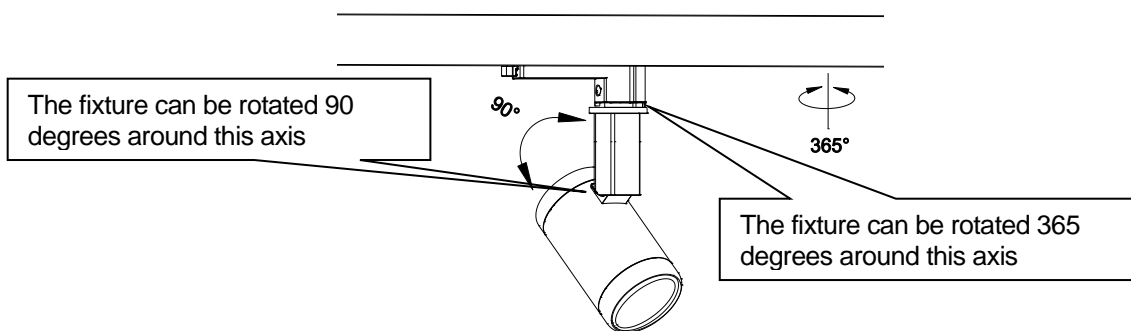

Light spot adjustment: (not available for fixed angle)

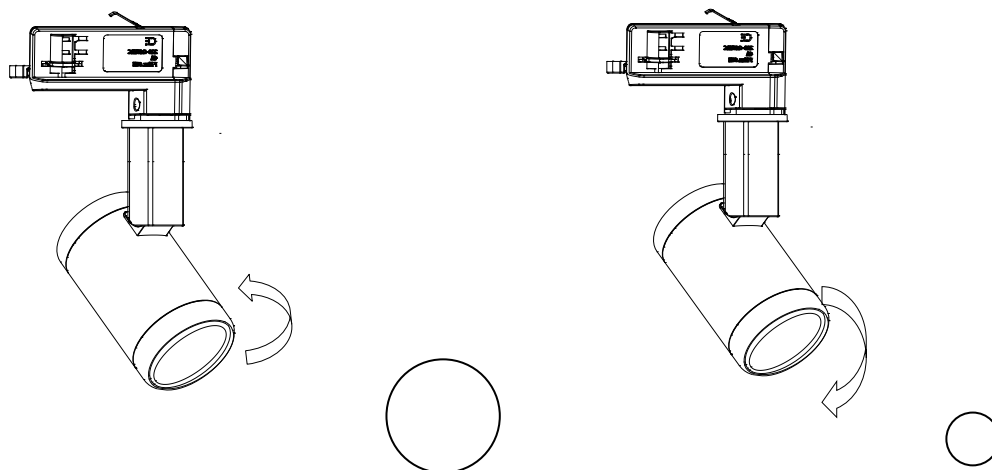

Diagram of maximum 55 °light spot

Diagram of minimum 10 °light spot

Rotate the "front frame" anticlockwise, closer to the LED, the larger the spot.

Rotate the "front frame" clockwise, away from the LED, the smaller the spot.

Dimming control component replacement:

1. The "0-10V&Knob" dimming control component can be replaced with a "DALI" dimming control component, both of which can be interchanged.
2. Operation steps:
 - 1) Rotate the "fixed ring" anticlockwise and remove the "0-10V&knob" dimming control component by hand;
 - 2) Align the seven core connector male and driver female of the "DALI" dimming control component and insert them tightly;
 - 3) Tighten the "fixing ring" clockwise to replace the DALI dimming control component. The specific instructions are shown in the following figure.

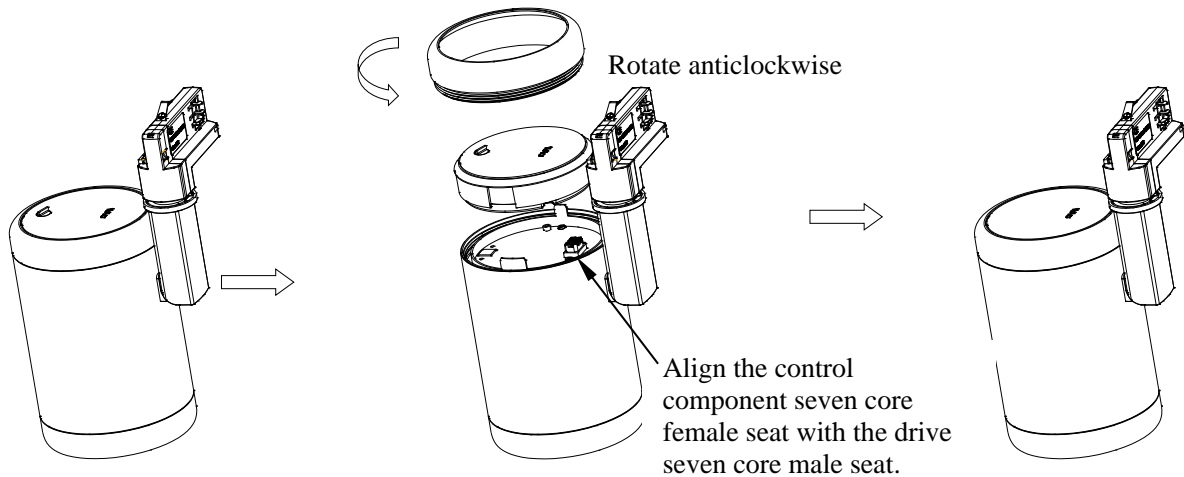

Single lens replacement and installation:

1. Lens replacement instructions: Gently shake the "front frame" by hand while pulling it out. When you see the marble, it means the front frame has been pulled out; (Fig. 6-1) (Handle with care, the "front frame" with lifting rope will not fall off the ground).
2. Twist the lens to the left with your hand and remove the original lens; (as show Fig. 6-2)
3. Align the prepared lens with the buckle on the bracket and turn it to the right. If you hear a click or feel that it can no longer be turned, complete the lens replacement; (as show Fig. 6-3)
4. Front frame installation: The plastic parts on the front frame have two notches. Align them with the two pillars on the lamp body, one wider and the other narrower. Press down and hear a click to complete the front frame installation; (as show Fig. 6-4)
5. The focusing lens can be replaced with a fixed angle lens: After pulling out the front frame, gently pry off the hook of the plastic part by hand, rotate the focusing lens out and place it in place (Fig. 6-5), then repeat the second operation (Fig. 6-3) to complete the focusing and angle replacement.

Note: The fixture images and AD heads are for reference only, and the actual model shall prevail.

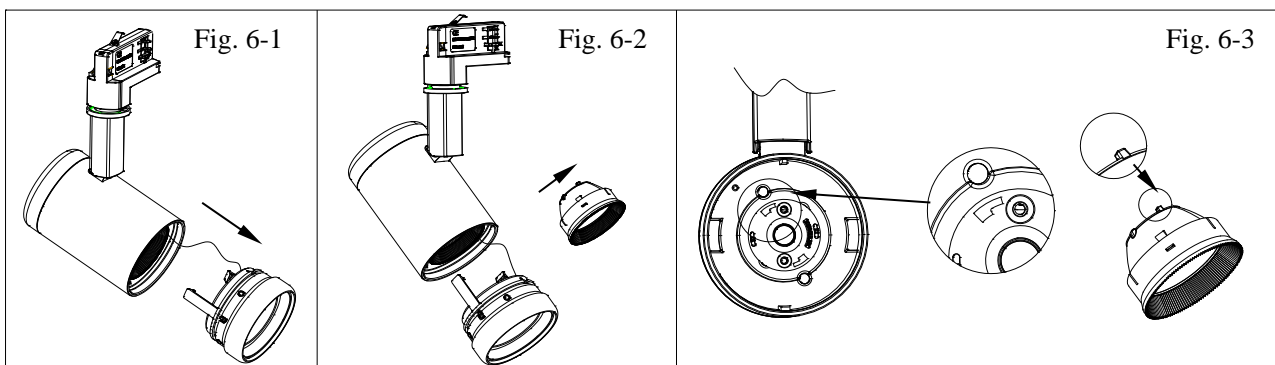

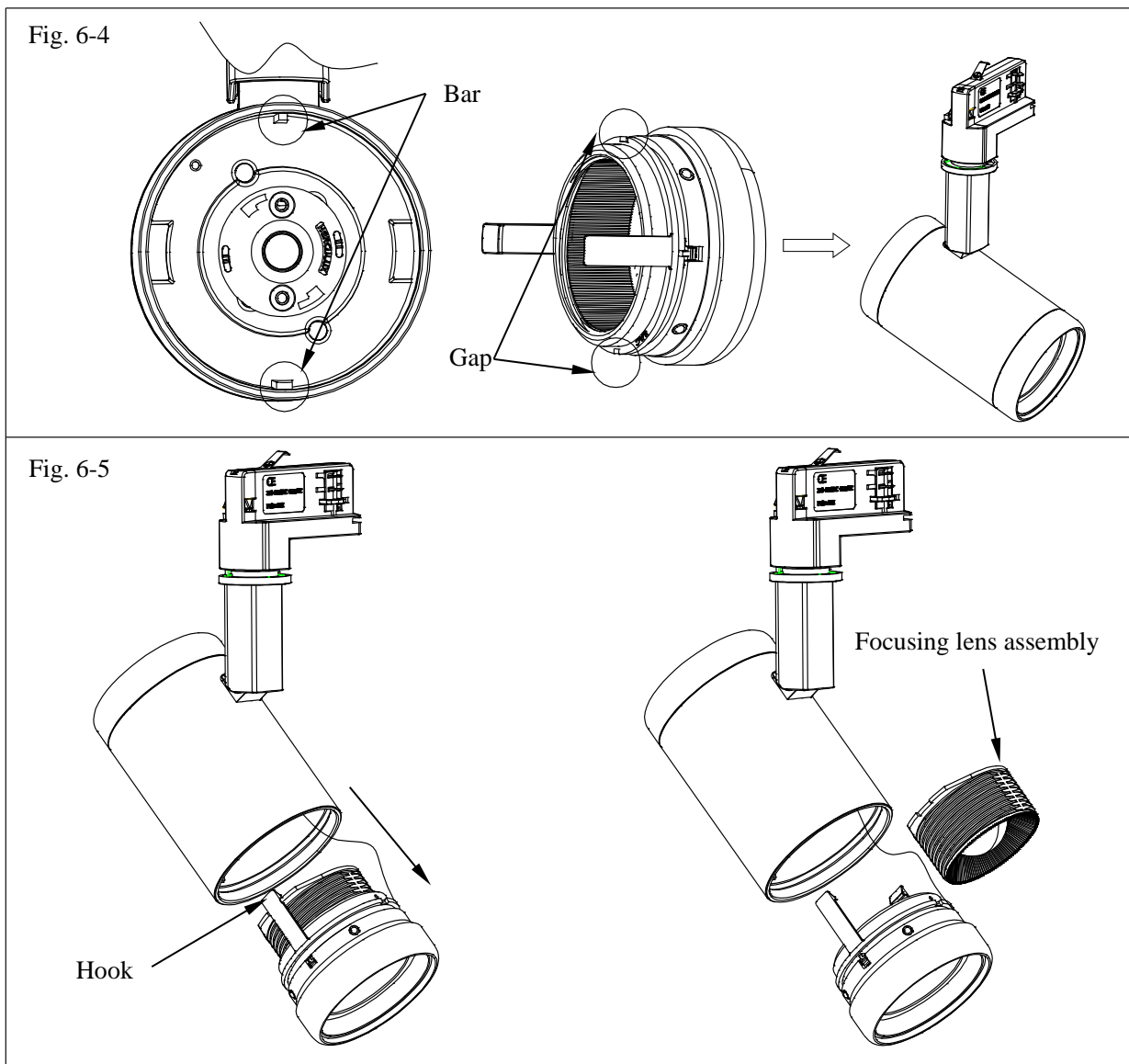

Multiple lens replacement and installation (not available in small angle series):

1. Lens replacement instructions: Gently shake the "front frame" by hand while pulling it out. When you see the marble, it means the front frame has been pulled out; (Fig. 7-1) (Handle with care, the "front frame" with lifting rope will not fall off the ground);
2. Press the "snap fastener" on the lens by hand, and the "snap fastener" will pop up to remove the original lens; (as show Fig. 7-2)
3. Take the prepared lens and align the "snap pin" with the "flat buckle" on the lamp body. When you hear a click, complete the lens replacement; (as show Fig. 7-3)
4. Front frame installation: The plastic parts on the front frame have two notches. Align them with the two pillars on the lamp body, one wider and the other narrower. Press down and hear a click to complete the front frame installation; (as show Fig. 7-4)

Note: The fixture images and AD heads are for reference only, and the actual model shall prevail.

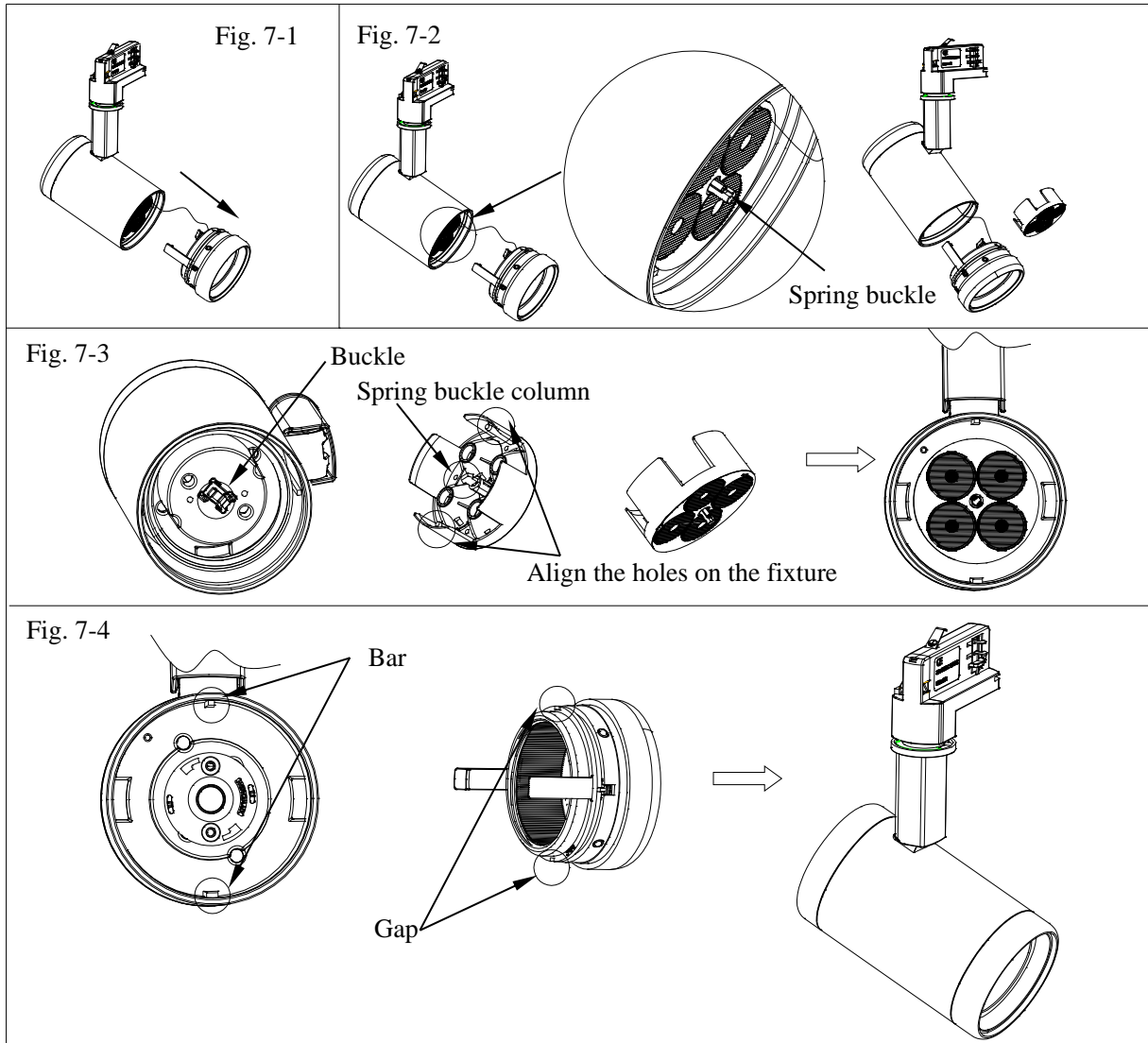

Replacement and installation of optical board accessories:

1. Please refer to the specifications for glass and optical panel accessories, and provide instructions for replacing them with new glass;

Note: The fixture images and AD heads are for reference only, and the actual model shall prevail.

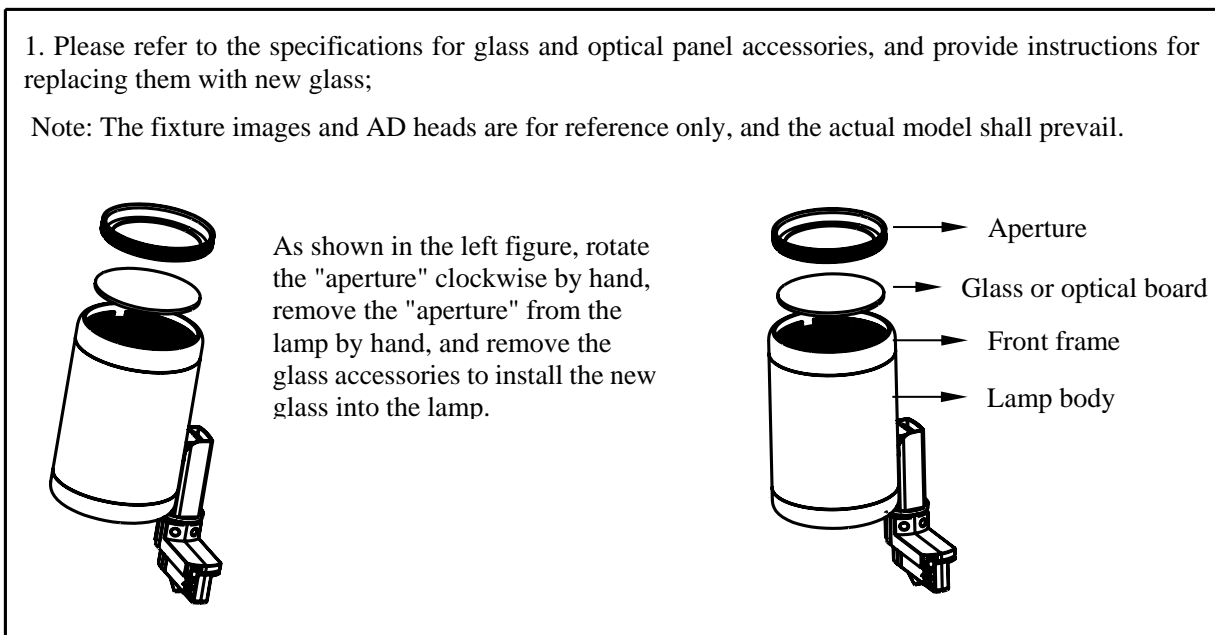

2. Please refer to the specifications for honeycomb accessories and instructions for disassembling and replacing the honeycomb;

Note: The fixture images and AD heads are for reference only, and the actual model shall prevail.

a. Rotate the "aperture" clockwise by hand and remove it from the lamp by hand, as shown in the following figure;

b. Replace the "honeycomb" and "glass", and tighten the "aperture" clockwise as shown in the following figure.

Note: When replacing accessories, the honeycomb has a large convex surface facing outward.

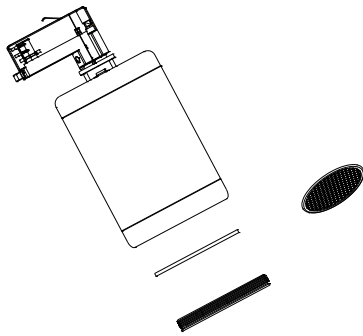

3. Please refer to the specifications for the accessories of the spotlight, and instructions for disassembling and replacing the spotlight;

Note: The fixture images and AD heads are for reference only, and the actual model shall prevail.

a. Rotate the "aperture" clockwise by hand and remove it from the lamp by hand, as shown in the following figure;

b. Install the spotlight tube into the lamp body and tighten it clockwise as shown in the following figure.

Note: When replacing accessories, the spotlight and honeycomb can be installed simultaneously.

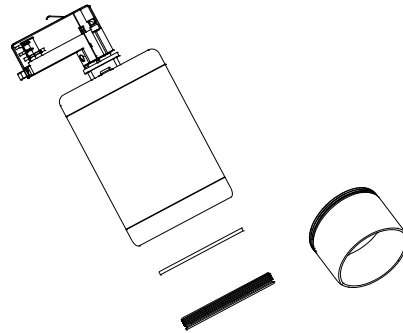

Installation method and maximum lifting capacity of the track system:

1. The track system can only be lifted;
2. The maximum weight that the track system can withstand is shown in the following figure, which includes the weight of the entire suspension system;
3. A single adapter can withstand a maximum load of 10kg (apply the load to the adapter according to the normal installation position of the lamp).

