

Product Type:

This installation instruction applies to Aether round recessed lighting series, product type KDA21*KDA31*KDA41*KDA51*KDA61*, where "*" contains information about different wattage of the lamps, different control systems, different color temperatures, different appearance of the color information.

Installation Precaution:

1. Please read the instructions carefully before installation;
2. Please have a professional electrician install it;
3. Please make sure the power is off before installation and maintenance to avoid the risk of electric shock;
4. Please do not cover the heat insulator and combustible materials above the light fixture and bulb after the light fixture is embedded in the surface of the ceiling of the installation to avoid causing fire;
5. Please replace the transparent protective glass immediately if it is cracked;
6. Please do not install the luminaire on unstable and unstable skylight to avoid falling of the luminaire;
7. Please keep the instruction manual for reference.

Fixture Installation:

I. KDA21* KDA31* KDA41* to be installed as follows:

1. Confirm adequate space on the ceiling for mounting the fixture (unit: mm), see Fig. (1), and the thickness of the ceiling T (unit: mm).
2. Dig a round hole with diameter ϕc (unit: mm) on the ceiling, see Fig. (2).

Model	Frame Diameter ϕa (mm)	Angled Fixture Height Hb (mm)	Opening Size ϕc (mm)	Ceiling Thickness (mm)
KDA21*	$\phi 62$	H74	$\phi 55$	5-15mm
KDA31*	$\phi 82$	H98	$\phi 75$	5-20mm
KDA41*	$\phi 110$	H132	$\phi 100$	5-25mm

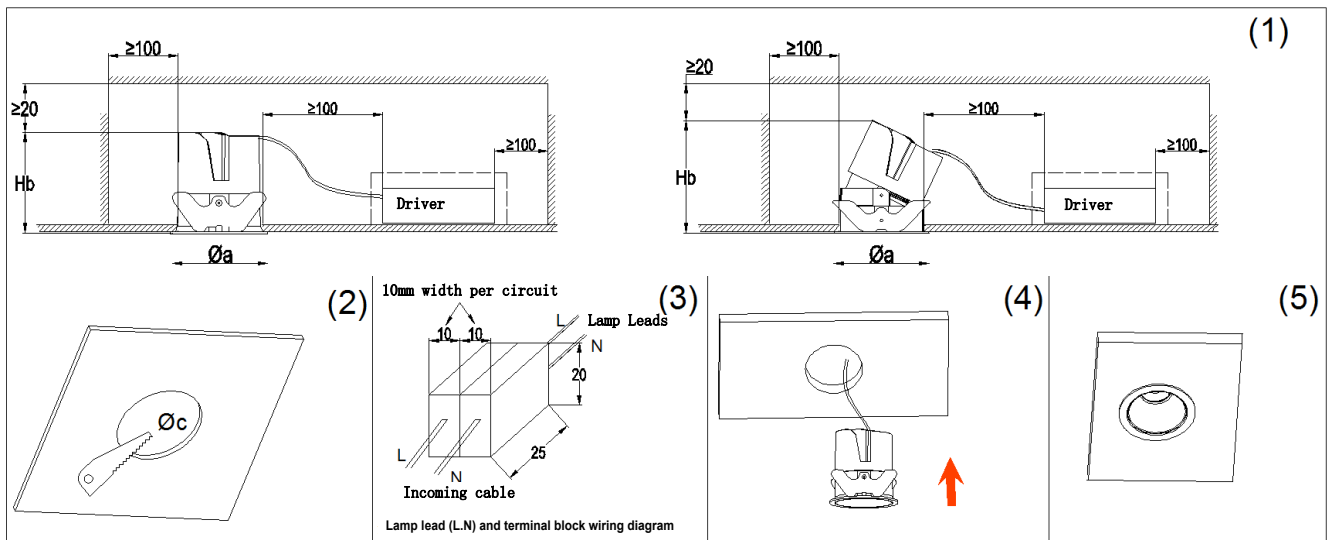

3. If the driver of the luminaire comes with its own lead, and this connection lead needs to be connected with an independent terminal block (refer to Figure (3) schematic wiring), the size of each terminal block should be not less than 10*20*25mm.
4. After the driver is connected to the power cord, feed the cord and driver into the ceiling. Hold the face frame of the fixture with the middle, ring and pinky fingers, and press the tabs toward the axis of the fixture with the thumb and forefinger until the tabs enter the ceiling holes.

(1) Installation of lamps without electrical appliances: the lamps have blue and brown lead wires and cannot be directly connected to 220V AC. Clients are responsible for their own electrical appliances, which need to match the light source; different control methods, the number and color of the lamps' lead wires are different (refer to the positive and negative polarity labels on the wires of the lamps), and they cannot be directly connected to 220V alternating current (AC). Matching light source is required for customer's own electrical appliances.

(2) Hold the fixture with both hands and feed it into the hole dug in the ceiling until the panel of the fixture is even with the surface of the ceiling. See Figure (5).

Authorized by WAC Lighting Corporation, USA, holder of the "WAC" trademark.

China Marketing Headquarters: WAC Lighting Technology (Shanghai) Co.
 Address: Room 102, No. 14, Lane 299, Bisheng Road, Pilot Free Trade Zone, Shanghai (201204), P.R.C.
 China Factory: Manufactured WAC Lighting(Dongguan)Co.,Ltd
 Address: No. 390, Qingfeng Road, Qingxi Town, Dongguan City, Guangdong Province, 523653, P.R. China

6. Angled fixtures can be angled horizontally or vertically.

- Find the rotating frame upward from the light outlet of the lamp, use two fingers to rotate the lamp 350° horizontally (KDA21* rotates 360° horizontally);
- After the horizontal direction is adjusted, using the index finger top adjusting angle orientation on the lamp body, and 0-25 degrees vertical angle adjustment;

II, KDA51*KDA61*to be installed as follows:

1. Confirm adequate space on the ceiling for mounting the fixture (unit: mm), see Fig. (1), and the thickness of the ceiling T (unit: mm).
2. Dig a round hole with diameter ϕc (unit: mm) on the ceiling, see Fig. (2).

Model	Frame Diameter ϕa (mm)	Angled Fixture Height Hb (mm)	Opening Size ϕc (mm)	Ceiling Thickness T (mm)
KDA51*	$\phi 135$	H168	$\phi 125$	1-20mm
KDA61*	$\phi 172$	H187	$\phi 160$	1-25mm

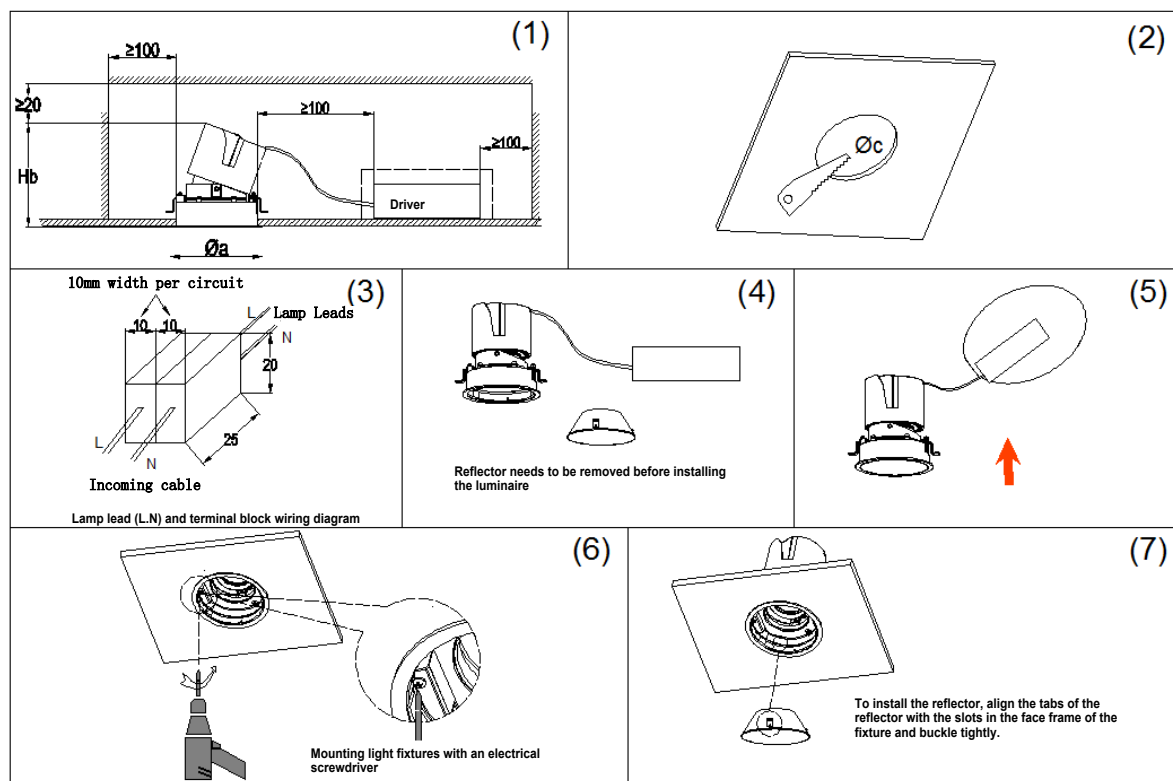

3. If the driver of the luminaire comes with its own lead, and this connection lead needs to be connected with a separate terminal block (see Figure (3) schematic wiring), the size of each terminal block should not be less than 10*20*25mm.
4. Remove the reflector before installing the fixture, see figure (4). Then the driver is connected to the power cord, feed the wire, driver, and fixture into the ceiling, see Figure (5). Turn the fixture's clamps with a electric screwdriver until the fixture locks securely, see Figure (6). Install the reflector, see figure (7).

(1)Fixture installation without electrical appliances: the fixture has blue and brown lead wires, and cannot be directly connected to 220V AC. Electrical appliances are provided by customers, which need to match the light source; the number and color of lead wires are different for different control modes (refer to the positive and negative polarity labels on the wires of the fixtures), and cannot be directly connected to 220V AC power. Matching light source is required for customer's own electrical appliances.

5. Angled fixtures can be angled horizontally or vertically.

- Find the rotating frame upward from the light outlet of the lamp, use two fingers to rotate the lamp 350° horizontally (KDA21* rotates 360° horizontally);
- After the horizontal direction is adjusted, using the index finger top adjusting angle orientation on the lamp body, and 0-25 degrees vertical angle adjustment;

Authorized by WAC Lighting Corporation, USA, holder of the "WAC" trademark.

China Marketing Headquarters: WAC Lighting Technology (Shanghai) Co.

Address: Room 102, No. 14, Lane 299, Bisheng Road, Pilot Free Trade Zone, Shanghai (201204), P.R.C.

China Factory: Manufactured WAC Lighting(Dongguan)Co,Ltd

Address: No. 390, Qingfeng Road, Qingxi Town, Dongguan City, Guangdong Province, 523653, P.R. China