

Product Type:

These installation instructions apply to LED underground lights EIR4TF, EIR4NF, EIR2TF, EIR2NF.

Installation Precaution:

1. Please read the instructions carefully before installation;
2. Please have it installed by a professional electrician;
3. To avoid the danger of electric shock, please make sure the power is turned off before installation and maintenance;
4. Please keep the instruction manual for reference.

Spring-loaded Recessed Mounting (EIR2*F):

1. First, open holes at the location where the luminaires are to be installed according to the corresponding models as shown in Fig. 1 ①, and refer to Table 1 for the dimensions of the openings;

Note: 1) In order to guarantee stable and safe installation of the luminaires, the openings of the luminaires must be made on hard material;
 (2) The bottom of the luminaires must be pre-buried drainpipes, to eliminate the water accumulation;

Fixture Model	Opening Dimensions $\varnothing A$
EIR2TF	$\varnothing 32\text{mm}$
EIR2NF	$\varnothing 48\text{mm}$

Table 1

2. As shown in Fig. 1 ②, connect the leads of the luminaires with the power cables in the junction box and make waterproof treatment (waterproof junction box needs to be purchased separately);
- 3.

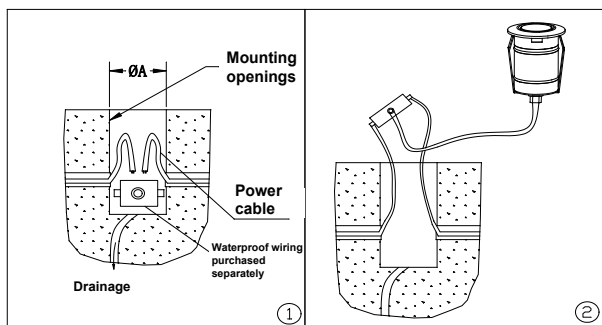

Figure I

4. As shown in Figure II ③, push the luminaires into the holes to flatten the flanges of the luminaires against the mounting surface;
5. Clean the surface of the light outlet of the luminaires as shown in Figure II ④.

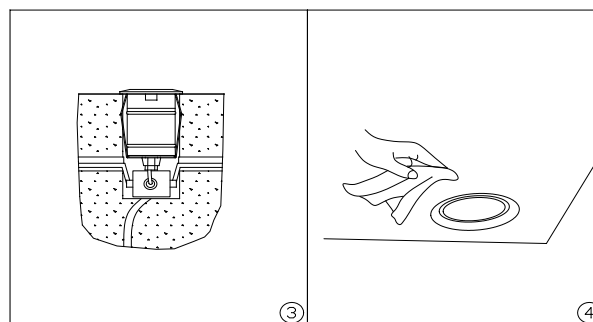

Figure II

Authorized by WAC Lighting Corporation, USA, holder of the "WAC" trademark.

China Marketing Headquarters:

WAC Lighting Technology (Shanghai) Co.

Address:

Room 102, No. 14, Lane 299, Bisheng Road, Pilot Free Trade Zone, Shanghai (201204), P.R.C.

China Factory:

Manufactured WAC Lighting(Dongguan)Co,Ltd

Address:

No. 390, Qingfeng Road, Qingxi Town, Dongguan City, Guangdong Province, 523653, P.R. China

Installation of pre-buried pipes (EIR4*F):

1. Cut holes for PVC pipes at the installation position of the lamp, as shown in Fig. 3 ①.
2. Fix the embedded parts with concrete as shown in Fig. 3 ②, and refer to Table 2 for the size of PVC pipes;

Fixture Model	Opening Dimensions $\varnothing A$	PVC Pipe I.D. Size $\varnothing D$	PVC Pipe Height
EIR4TF	$\varnothing 33\text{mm}$	$\varnothing 28\text{mm} \pm 0.3\text{mm}$	$70\text{mm} \pm 0.5\text{mm}$
EIR4NF	$\varnothing 51\text{mm}$	$\varnothing 44\text{mm} \pm 0.3\text{mm}$	$70\text{mm} \pm 0.5\text{mm}$

Table 2

3. Connect the leads of the luminaires with the power cord in the waterproof junction box to make waterproof treatment, as shown in Figure III ②;

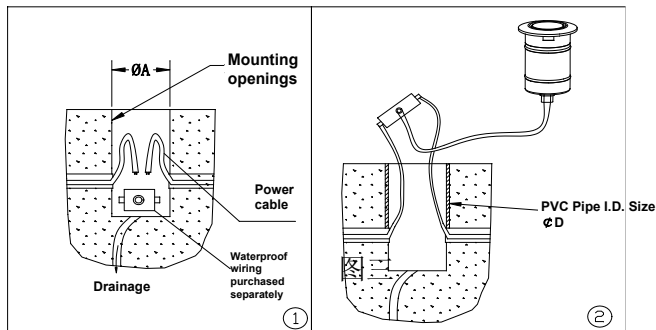
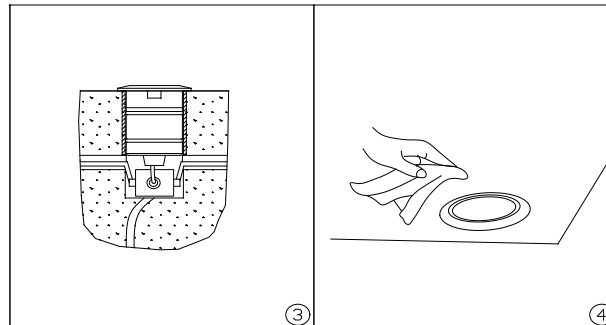

Figure III

4. Install the luminaires into the PVC pipe and make sure the flange of the luminaires is even with the mounting surface as shown in Figure IV ③;
5. Clean the surface of the light outlet of the luminaires, as shown in Fig. 4 (4).

Figure IV



Dismantling and Maintenance:

When the luminaire needs to be dismantled for maintenance, please refer to Figure V.

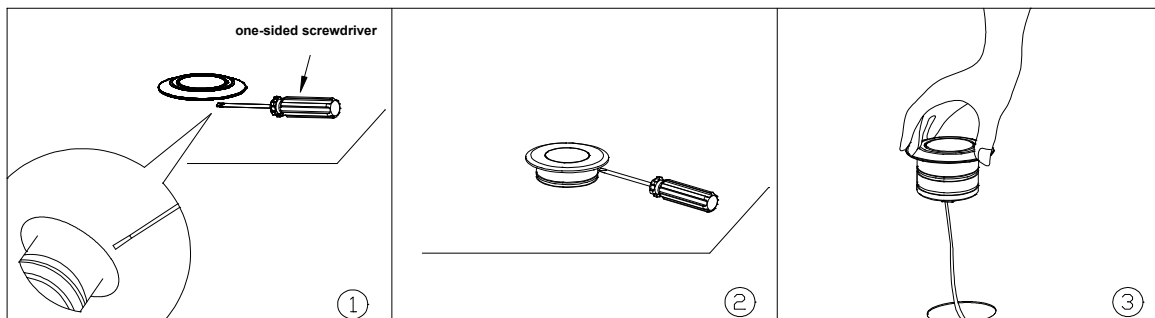

Figure V

Authorized by WAC Lighting Corporation, USA, holder of the "WAC" trademark.

China Marketing Headquarters:

WAC Lighting Technology (Shanghai) Co.

Address:

Room 102, No. 14, Lane 299, Bisheng Road, Pilot Free Trade Zone, Shanghai (201204), P.R.C.

China Factory:

Manufactured WAC Lighting(Dongguan)Co,Ltd

Address:

No. 390, Qingfeng Road, Qingxi Town, Dongguan City, Guangdong Province, 523653, P.R. China

Wiring Instructions:

For fixture wiring, please refer to Figure VI.

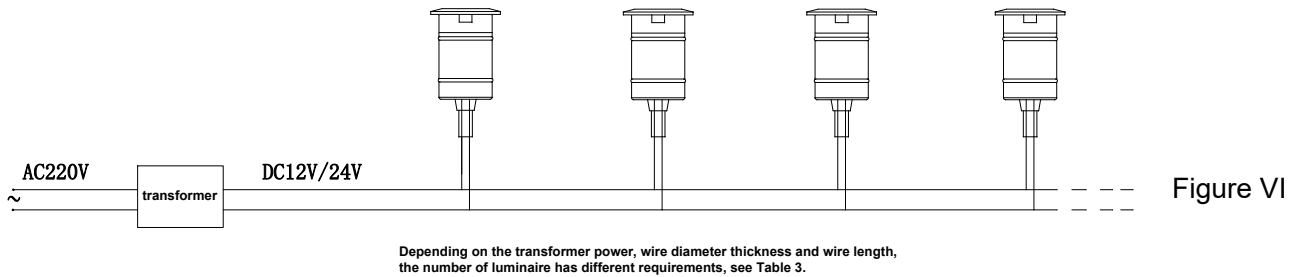

Please refer to Table 3 for the number of transformers, wire diameters and stringing of luminaires:

No.	Transformer Power (W)	wire diameter (mm ²)	Cable Length (m)	Suggested number of luminaire in series (pcs)	
				Fixture Power 4.5W	Fixture Power 2W
1	100	1.0	50	10	21
2	100	1.0	40	11	23
3	100	1.0	30	12	25
4	100	1.0	20	13	28
5	100	1.0	10	14	30

Table 3

Note: • The wire diameters in the table are the wire diameters of the wires at the output of the transformer;

- The wires in the table are standard copper core conductors;
- The transformer load capacity in the table is 100%, if the load capacity decreases, it will be adjusted proportionally;
- Method of calculating the number of connected luminaires in the table: if the power of the transformer is changed to 200W, the number of connected luminaires should be increased accordingly. In order to ensure that the current-carrying capacity of the wire is not overloaded, the wire diameter must also be increased according to the corresponding ratio.

Authorized by WAC Lighting Corporation, USA, holder of the "WAC" trademark.

China Marketing Headquarters: WAC Lighting Technology (Shanghai) Co.
 Address: Room 102, No. 14, Lane 299, Bisheng Road, Pilot Free Trade Zone, Shanghai (201204), P.R.C.
 China Factory: Manufactured WAC Lighting(Dongguan)Co,Ltd
 Address: No. 390, Qingfeng Road, Qingxi Town, Dongguan City, Guangdong Province, 523653, P.R. China