

Model:

This installation instruction is applicable to the ELANAI wall washing lamp DWF * series, where "*" includes information on different power, control systems, color temperatures, face frames, and appearance colors of the lamp.

Installation Precautions:

1. Please read through the Instructions before installation;
2. The product should be installed by a professional electrician;
3. Make sure the power supply is cut off before installation and maintenance, to avoid the risk of electric shock;
4. Luminaires can be embedded into the ceiling surface for installation, but do not cover insulation and combustibles above the lamps and bulbs to avoid causing fires;
5. Do not install the lighting fixtures on unstable and unstable skylights to prevent them from falling;
6. Please keep this Instruction properly for future reference.

Light Installation and Wiring:

1. Installation parameters:

MODEL	X Max	Y	Z	D(Cut out)	H(Ceiling thickness)
DWF31*	1m	$\leq X$	$\leq 3X$	$\Phi 78\text{mm}$	1~25mm
DWF35*	1m	$\leq X$	$\leq 3X$	$\Phi 78\text{mm}$	1~25mm

DWF31 Series

DWF35 Series

2. Installation method and step:

- (1) Confirm that there is sufficient space on the ceiling to install lighting fixtures (unit: mm);
- (2) Digging diameter on the ceiling ϕ 78mm circular hole;

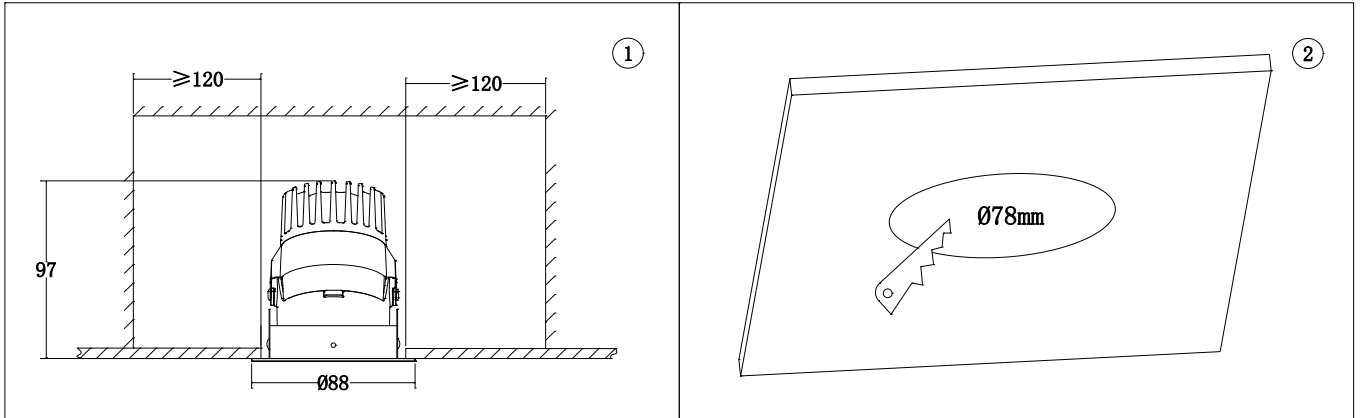

- (3) If the electrical appliance of the lamp comes with a lead wire, and this connecting lead wire needs to be connected to an independent terminal block (refer to the schematic diagram in Figure 3 for wiring), the size of each terminal block should not be less than 10x20x25mm
- (4) Installation of electrical series lighting fixtures: Connect the power cord to the driver, send the wire and driver into the ceiling, and press the spring towards the axis of the lighting fixture with both thumbs, index and middle fingers until the spring enters the ceiling hole.

Installation of lamps without electrical appliances: The lamps have red and black lead wires and cannot be directly connected to 220V AC power. The customer provides their own electrical appliances, which need to be matched with a light source.

- (5) Hold the lamp with both hands and insert it into the ceiling hole until the lamp panel is flush with the surface of the ceiling.

