

Model:

This installation manual applies to the ELF603/703- * series, ELF605/705- * series, and ELF610/710- * series of LED outdoor hard-strip lights, where the "*" indicates different powers, control systems, light angles, color temperatures, and appearance colors of the lamps.

Installation Precautions:

1. Please read through the Instructions before installation.
2. The product should be installed by a professional electrician.
3. Make sure the power supply is cut off before installation and maintenance, to avoid the risk of electric shock.
4. Before installing the lighting fixtures, please confirm that the installation surface is firm and reliable to prevent the fixtures from falling.
5. Please keep this Instruction properly for future reference.

Light Installation and Wiring:

1. Rotate and fix the stainless steel bracket to a certain angle, installing two supports for the lamp. The distance between the fixing holes of the brackets is shown in Figure 1 (self-tapping screws and plastic geckos to be provided by the construction party);
2. Drill holes according to the position of the stainless steel bracket, install the plastic gecko, and secure the installation bracket with self-tapping screws, as shown in Figures 2 and 3;
3. To install adjacent light strips, it is necessary to first wire, then drill holes, install plastic geckos, and finally secure the lighting fixtures. The power cords of the fixtures are distinguished with input and output terminal directions. Please wire according to the label on the wire, as shown in Figures 5, 6, and 7;
4. The adjustable-angle bracket can be adjusted from left to right by 90 degrees, and the fixed light fixture is vertically acing upwards, as shown in Figure 4;

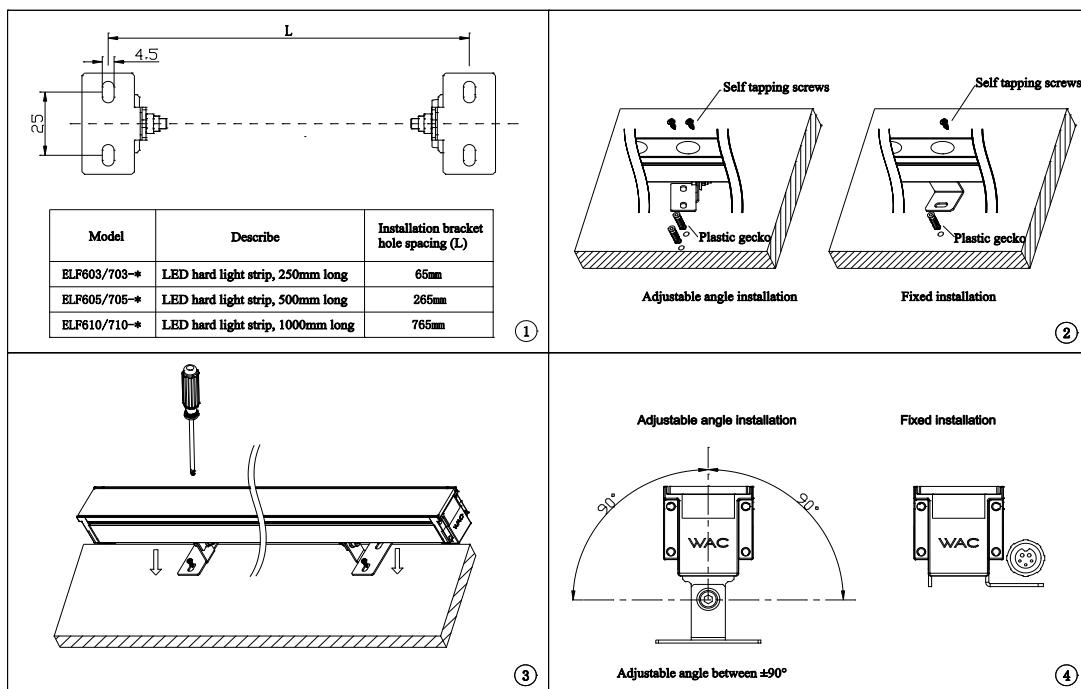

5. The ON-OFF version of the lighting fixture wiring is as shown in Figure 5;

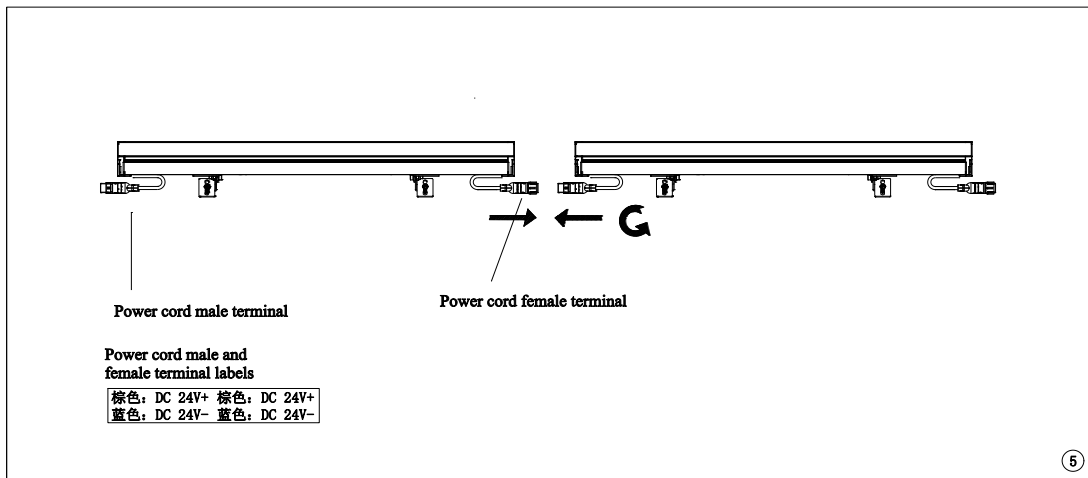

6. The 0-10V version of the lighting fixture wiring is as shown in Figure 6;

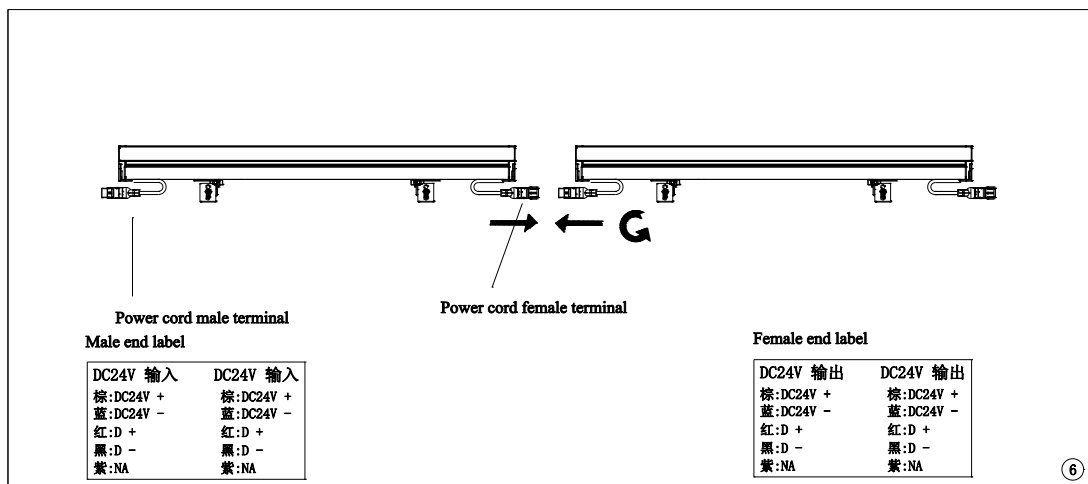

7. The DMX512 version of the lighting fixture wiring is as shown in Figure 7;

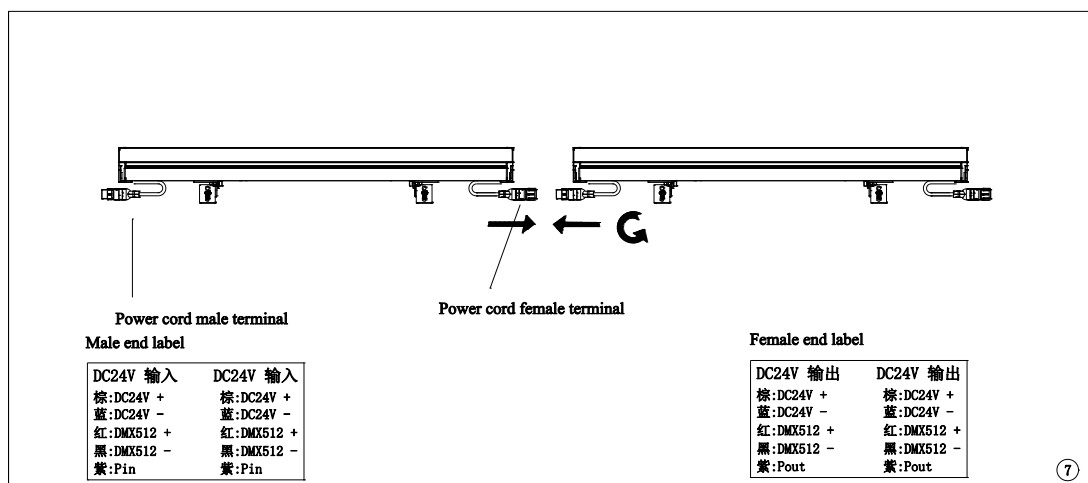

8. The lighting fixtures are wired according to the schematic diagram below, as shown in the figure:

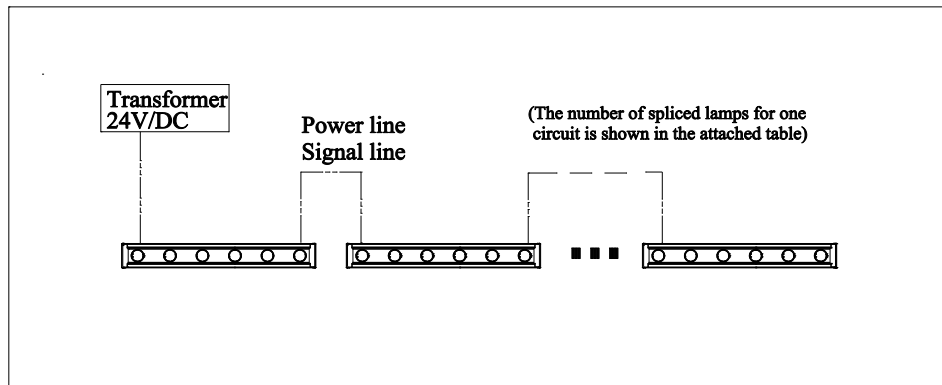

Note: The connection of the power cord should be made using the waterproof connector wire provided by our company. It is recommended that the number of splices for each power circuit connected to the lighting fixtures is shown in Table 1, and the current should not exceed 8A.

9. The wiring of DMX512 version lighting fixtures is as follows, as shown in the figure:

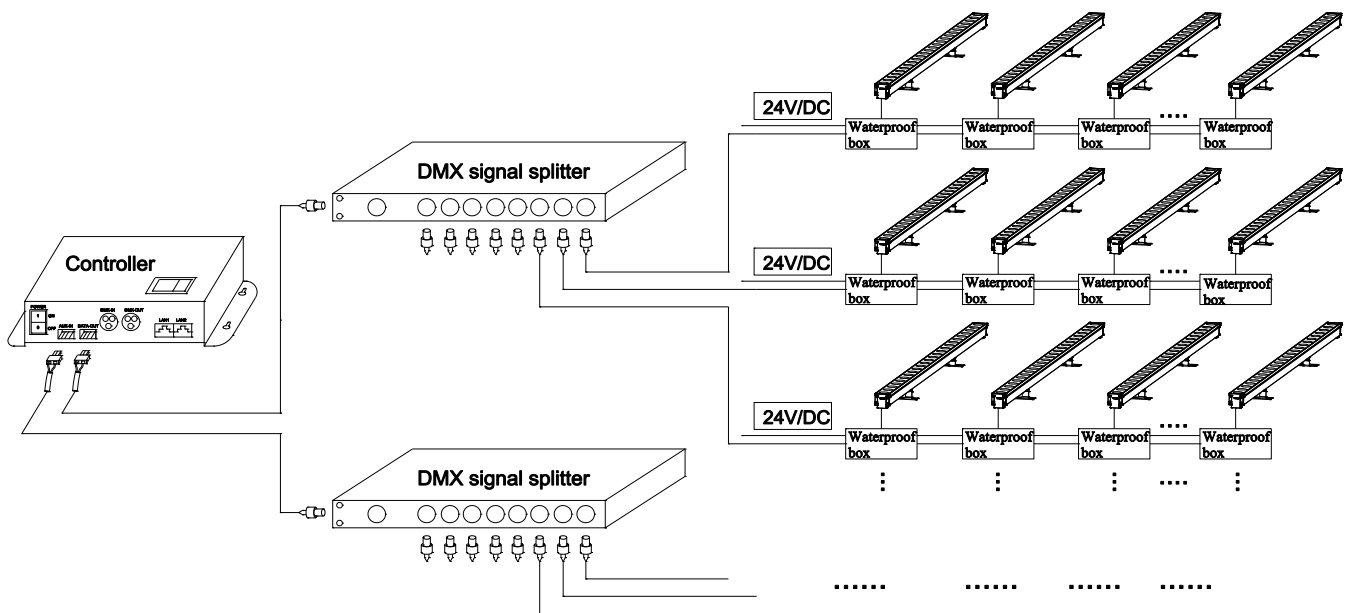

Note: The wire connection must use a waterproof junction box with an IP65 or higher rating, and the waterproof joints of the junction box must match the leads of the lighting fixtures. It is recommended to splice the number of lighting fixtures connected to each power circuit as shown in Table 1. It is advisable to have no more than 26 lighting fixtures loaded on each DMA signal amplifier.

10. Suggest the installation position of the lamp from the illuminated surface, as shown in Table 2 below:

LED power	Suggest the number of splices per circuit
48W/M	4PCS
36W/M	6PCS
24W/M	8PCS

Table 1

Lens scheme/power	Suggested installation location
Single 48W/m	200mm away from the wall
Single 36W/m	150mm away from the wall
Single 24W/m	100mm away from the wall
Integrated lens	50mm away from the wall

Table 2