

### Installation Precautions:

1. Please read the manual carefully before installation and have a professional electrician install it;
2. To avoid the risk of electric shock, please confirm to turn off the power before installation and maintenance;
3. Before installing the lighting fixtures, please confirm that the installation surface is firm and reliable to prevent the fixtures from falling;
4. Lighting fixtures are not suitable for being covered by insulation materials;
5. The light source of this lamp is irreplaceable. When the light source reaches its end of life, the entire lamp should be replaced;
6. If the external flexible cable or cord of this lamp is damaged, the cable should be replaced by the manufacturer or its service agent or a qualified person to avoid danger;
7. Keep the instruction manual for reference only.

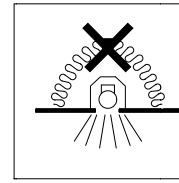

Warning: See signs. Under no circumstances should lighting fixtures be covered with insulation pads or similar materials

### Install lighting fixtures:

LAMP MODELS	SIZE OF CEILING OPENINGS	MINIMUM INSTALLATION SPACE (H)	RANGE OF INSTALLABLE CEILING THICKNESS (D)
ER301*	41×130mm	90mm	1~25mm
ER303*	41×242mm	90mm	1~25mm
ER305*	41×466mm	90mm	1~25mm

1. Select the corresponding ceiling opening size according to the specifications and models of the lighting fixtures, and pre open the installation holes for the lighting fixtures on the ceiling (as shown in Figure 1):

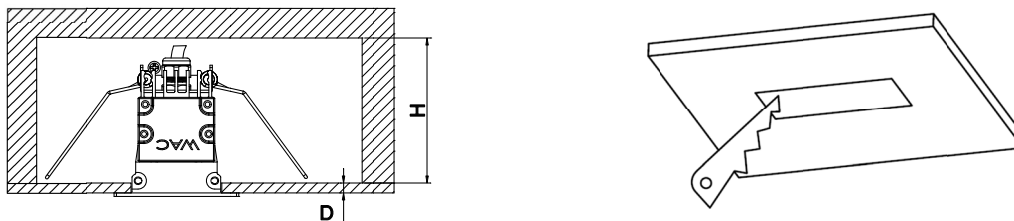

Figure 1

2. Lamp wiring: Connect the power input line of the lamp to the mains power line, and pay attention to the waterproof treatment of the wire connection (as shown in Figure 2):

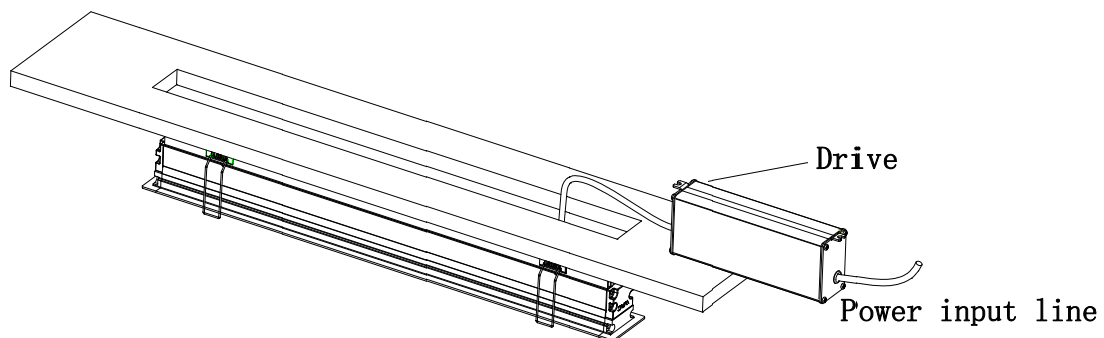

Figure 2

3. If the driver of the lamp comes with a lead wire, and this connecting lead wire needs to be connected to an independent terminal block (refer to the schematic diagram in Figure 3 for wiring), each path should be connected. The size of the wire terminal block should not be less than 10x20x25mm (pay attention to waterproof treatment at the wiring junction).

4. After connecting the wires, first insert the driver or junction box into the interior of the ceiling through the ceiling opening; Then twist the springs at both ends by hand and install the lamp into the ceiling opening.(As shown in Figure 4).

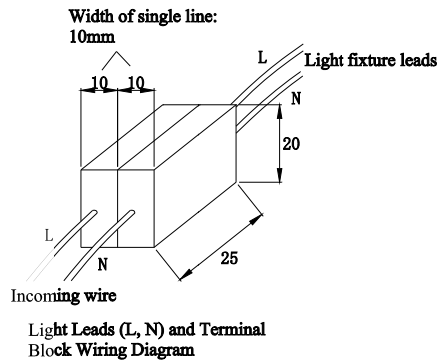

Figure 3

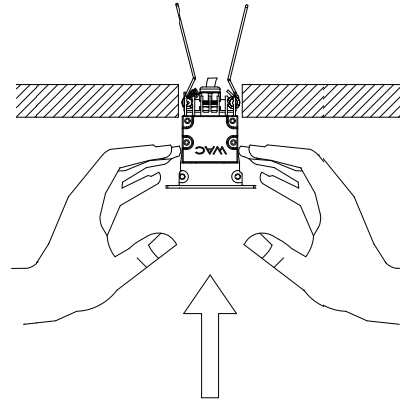

Figure 4

### Replacing and repairing lighting fixtures:

When replacing or repairing lamps, the disassembly process is opposite to the installation sequence. When disassembling, it is necessary to hold the lamp to prevent it from fallin