

Installation Precautions:

1. Please read through the Instructions before installation.
2. The product should be installed by a professional electrician.
3. Make sure the power supply is cut off before installation and maintenance, to avoid the risk of electric shock.
4. The light can be recessed on the ceiling, where sufficient space must be reserved for installation. Do not cover the light with any thermal insulation or consumable articles to avoid fire hazards.
5. In case of cracking of glass, please replace it immediately.
6. Do not install the light on an unstable or unsolid skylight, to avoid falling off.
7. Please keep this Instruction properly for future reference.
8. The LED source in the light should be replaced by the manufacturer or its service agent or similarly qualified personnel.

Product size(unit:mm):

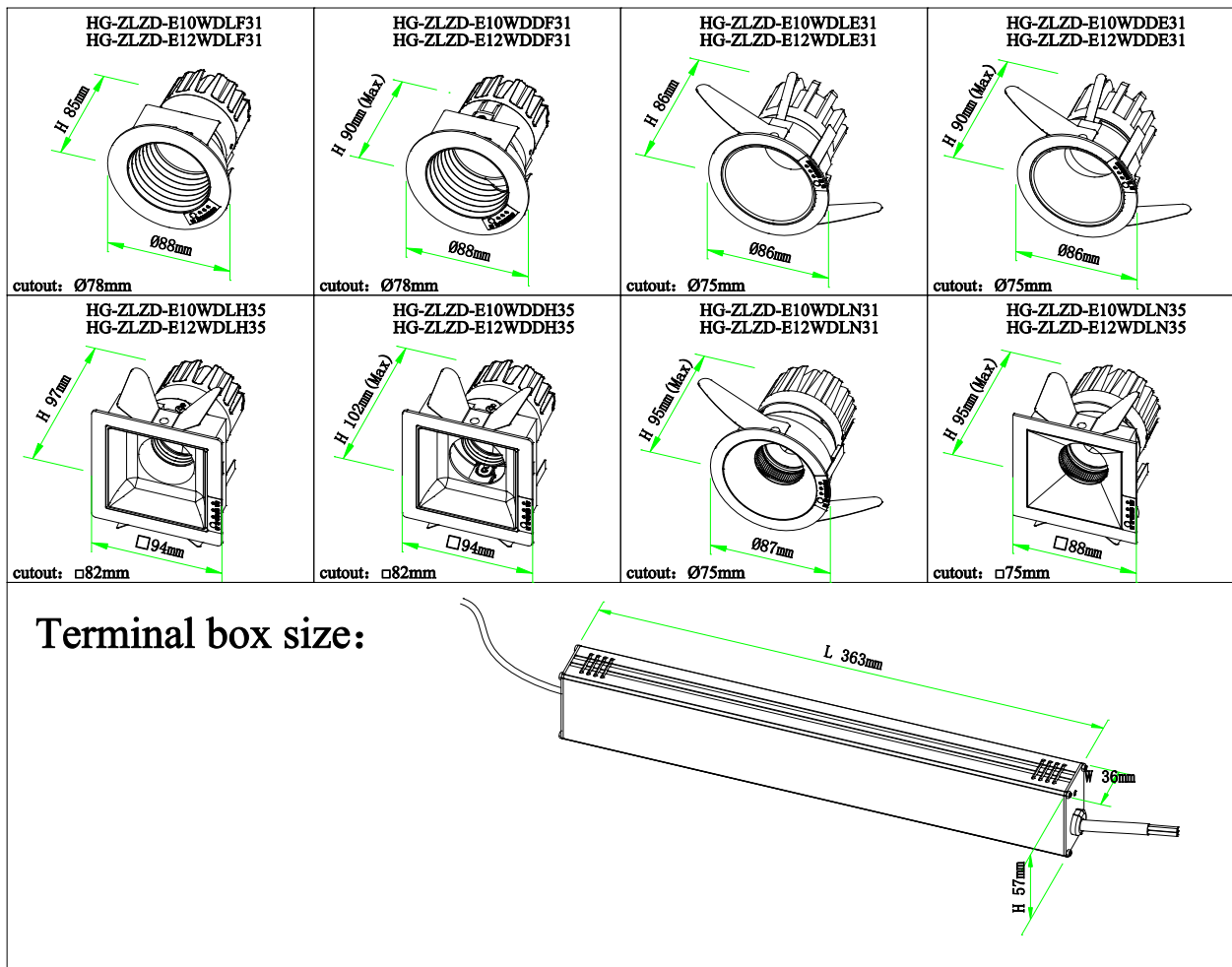

Lamp installation (taking HG-ZLZD-E10WDLF31 as an example, other models are similar):

1. Remove the product from the packaging box and check if the lighting accessories are complete before installation;

Licensed by "WAC" trademark holder - WAC LIGHTING, USA

Chinese Marketing Headquarters

: WAC Lighting (Shanghai) Co, Ltd.

: 14, Lane 299, Bi Sheng Road, Shanghai 201204, China

Address

China factory

Address

: Manufactured WAC Lighting (Dongguan) Co, Ltd.

: 390, Qingfeng Road, Qingxi Town, Dnguan, Guangdong. Postal code: 523653

2. Confirm that there is sufficient space on the ceiling to install lighting fixtures (in millimeters), and ensure that the width direction can accommodate the electrical box;
3. Dig the diameter on the ceiling $\varnothing 78\text{mm}$ circular hole (the hole size varies for different lamp models, please refer to product dimensions for details);

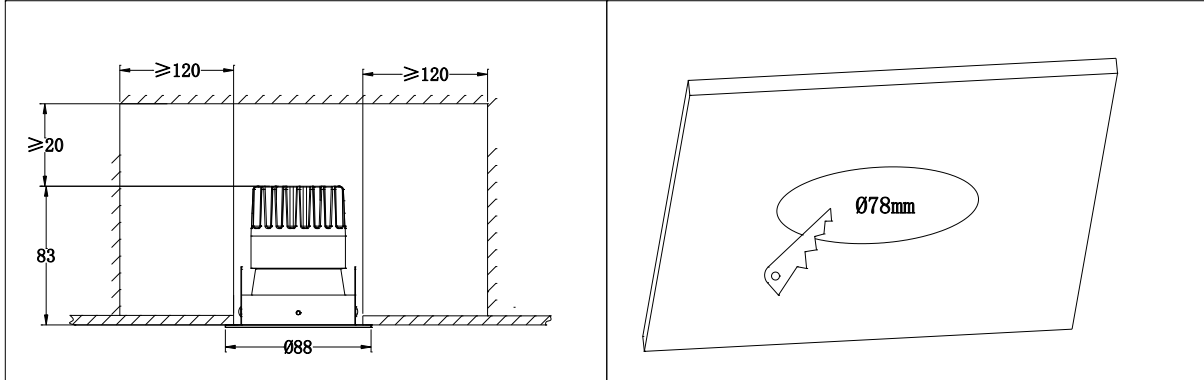

4. Connect the power input line of the lighting fixture to the corresponding power supply system, with a brown live wire, a blue neutral wire, a black switch wire (in phase with the live wire), and a yellow green ground wire;

Warning: If the external flexible cable of the lamp is damaged, it needs to be replaced by professional personnel to avoid danger!

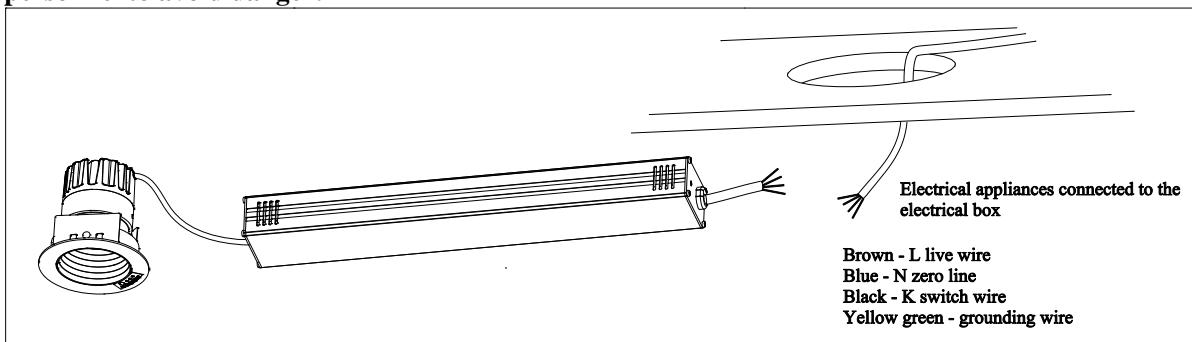

5. After connecting the power cord to the input wire of the electrical box, send the wire and electrical box into the ceiling. Use both thumbs, index and middle fingers to press the spring towards the axis direction of the lamp until the spring enters the ceiling hole;
6. Hold the lamp with both hands and insert it into the ceiling hole until the lamp panel is flush with the surface of the ceiling;
7. When connecting the AC 220V mains power, the lamp should be in the main power state, and then press the test button to check whether the emergency state of the test lamp is working properly.

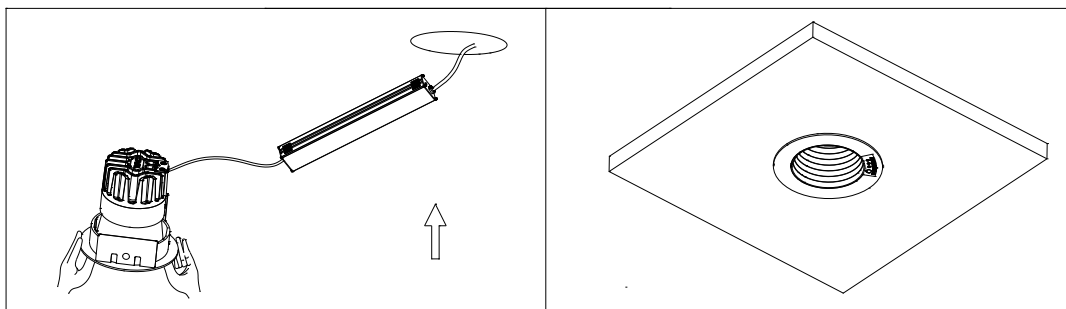

Specification:

1. Downlight style

Product series: HG-ZLZD-E10WDLF31
product name: Fire emergency lighting fixtures
rated supply voltage: 220V~50Hz
Light source name/parameters: LED/DC
31V-37V
Executive standard: GB17945-2010
Emergency output luminous flux:>50lm
Main power consumption: 10W
Shell protection level: IP30
Emergency working time: 90 minutes
Battery model and specifications: Li-ion 18650
2200mAh 3.7V 8.14Wh

Product series: HG-ZLZD-E12WDLF31
Product Name: Fire Emergency Lighting
Fixtures
Rated power supply voltage: 220V~50Hz
Light source name/parameters: LED/DC
31-37V
Executive standard: GB17945-2010
Emergency output luminous flux:>50lm
Main power consumption: 12W
Shell protection level: IP30
Emergency working time: 90 minutes
Battery model and specifications: Li-ion 18650
2200mAh 3.7V 8.14Wh

Product series: HG-ZLZD-E10WDLE31
Product Name: Fire Emergency Lighting
Fixtures
Rated power supply voltage: 220V~50Hz
Light source name/parameters: LED/DC
31V-37V
Executive standard: GB17945-2010
Emergency output luminous flux:>50lm
Main power consumption: 10W
Shell protection level: IP30
Emergency working time: 90 minutes
Battery model and specifications: Li-ion 18650
2200mAh 3.7V 8.14Wh

Product series: HG-ZLZD-E12WDLE31
Product Name: Fire Emergency Lighting
Fixtures
Rated power supply voltage: 220V~50Hz
Light source name/parameters: LED/DC
31-37V
Executive standard: GB17945-2010
Emergency output luminous flux:>50lm
Main power consumption: 12W
Shell protection level: IP30
Emergency working time: 90 minutes
Battery model and specifications: Li-ion 18650
2200mAh 3.7V 8.14Wh

Product series: HG-ZLZD-E10WDLH35
Product Name: Fire Emergency Lighting Fixtures
Rated power supply voltage: 220V~50Hz
Light source name/parameters: LED/DC 31V-37V
Executive standard: GB17945-2010
Emergency output luminous flux:>50lm
Main power consumption: 10W
Shell protection level: IP30
Emergency working time: 90 minutes
Battery model and specifications: Li-ion 18650 2200mAh 3.7V 8.14Wh

Product series: HG-ZLZD-E12WDLH35
Product Name: Fire Emergency Lighting Fixtures
Rated power supply voltage: 220V~50Hz
Light source name/parameters: LED/DC 31-37V
Executive standard: GB17945-2010
Emergency output luminous flux:>50lm
Main power consumption: 12W
Shell protection level: IP30
Emergency working time: 90 minutes
Battery model and specifications: Li-ion 18650 2200mAh 3.7V 8.14Wh

Product series: HG-ZLZD-E10WDLN31
Product Name: Fire Emergency Lighting Fixtures
Rated power supply voltage: 220V~50Hz
Light source name/parameters: LED/DC 31V-37V
Executive standard: GB17945-2010
Emergency output luminous flux:>50lm
Main power consumption: 10W
Shell protection level: IP30
Emergency working time: 90 minutes
Battery model and specifications: Li-ion 18650 2200mAh 3.7V 8.14Wh

Product series: HG-ZLZD-E12WDLN31
Product Name: Fire Emergency Lighting Fixtures
Rated power supply voltage: 220V~50Hz
Light source name/parameters: LED/DC 31-37V
Executive standard: GB17945-2010
Emergency output luminous flux:>50lm
Main power consumption: 12W
Shell protection level: IP30
Emergency working time: 90 minutes
Battery model and specifications: Li-ion 18650 2200mAh 3.7V 8.14Wh

Product series: HG-ZLZD-E10WDLN35
Product Name: Fire Emergency Lighting Fixtures
Rated power supply voltage: 220V~50Hz
Light source name/parameters: LED/DC 31V-37V
Executive standard: GB17945-2010
Emergency output luminous flux:>50lm
Main power consumption: 10W
Shell protection level: IP30
Emergency working time: 90 minutes
Battery model and specifications: Li-ion 18650 2200mAh 3.7V 8.14Wh

Product series: HG-ZLZD-E12WDLN35
Product Name: Fire Emergency Lighting Fixtures
Rated power supply voltage: 220V~50Hz
Light source name/parameters: LED/DC 31-37V
Executive standard: GB17945-2010
Emergency output luminous flux:>50lm
Main power consumption: 12W
Shell protection level: IP30
Emergency working time: 90 minutes
Battery model and specifications: Li-ion 18650 2200mAh 3.7V 8.14Wh

2. Angle adjustment style

Product series: HG-ZLZD-E10WDDF31
Product Name: Fire Emergency Lighting Fixtures
Rated power supply voltage: 220V~50Hz
Light source name/parameters: LED/DC 31V-37V
Executive standard: GB17945-2010
Emergency output luminous flux:>50lm
Main power consumption: 10W
Shell protection level: IP30
Emergency working time: 90 minutes
Battery model and specifications: Li ion 18650 2200mAh 3.7V 8.14Wh

Product series: HG-ZLZD-E12WDDF31
Product Name: Fire Emergency Lighting Fixtures
Rated power supply voltage: 220V~50Hz
Light source name/parameters: LED/DC 31-37V
Executive standard: GB17945-2010
Emergency output luminous flux:>50lm
Main power consumption: 12W
Shell protection level: IP30
Emergency working time: 90 minutes
Battery model and specifications: Li ion 18650 2200mAh 3.7V 8.14Wh

Product series: HG-ZLZD-E10WDDE31
Product Name: Fire Emergency Lighting Fixtures
Rated power supply voltage: 220V~50Hz
Light source name/parameters: LED/DC 31V-37V
Executive standard: GB17945-2010
Emergency output luminous flux:>50lm
Main power consumption: 10W
Shell protection level: IP30
Emergency working time: 90 minutes
Battery model and specifications: Li ion 18650 2200mAh 3.7V 8.14Wh

Product series: HG-ZLZD-E12WDDE31
Product Name: Fire Emergency Lighting Fixtures
Rated power supply voltage: 220V~50Hz
Light source name/parameters: LED/DC 31-37V
Executive standard: GB17945-2010
Emergency output luminous flux:>50lm
Main power consumption: 12W
Shell protection level: IP30
Emergency working time: 90 minutes
Battery model and specifications: Li ion 18650 2200mAh 3.7V 8.14Wh

Product series: HG-ZLZD-E10WDDH35

Product Name: Fire Emergency Lighting Fixtures

Rated power supply voltage: 220V~50Hz

Light source name/parameters: LED/DC 31V-37V

Executive standard: GB17945-2010

Emergency output luminous flux:>50lm

Main power consumption: 10W

Shell protection level: IP30

Emergency working time: 90 minutes

Battery model and specifications: Li ion 18650 2200mAh 3.7V 8.14Wh

Product series: HG-ZLZD-E12WDDH35

Product Name: Fire Emergency Lighting Fixtures

Rated power supply voltage: 220V~50Hz

Light source name/parameters: LED/DC 31-37V

Executive standard: GB17945-2010

Emergency output luminous flux:>50lm

Main power consumption: 12W

Shell protection level: IP30

Emergency working time: 90 minutes

Battery model and specifications: Li ion 18650 2200mAh 3.7V 8.14Wh

Performance and usage instructions:

There are three color indicator lights on the lamp: red (charging), green (main power), and yellow (fault), one each (or one red yellow green indicator light), one test button, and one buzzer (inside the electrical box).

Main power: Green indicator light. When this indicator light is on for a long time, it indicates that the mains power is normal (note: this light has a voltage automatic conversion circuit. If the mains voltage is around 150V, the lamp will switch from the main power state to the emergency state. When the mains voltage rises to around 170V, the lamp will automatically restore the main power state from the emergency state. When using this lamp, check whether the input AC voltage is normal). This indicator light flashes slowly, indicating that the lamp has entered the monthly inspection status. This indicator light flashes quickly to indicate that the lamp has entered the annual inspection status.

Charging: Red indicator light. When the AC input terminal of the lamp is connected to the AC220V power supply, the circuit inside the light will automatically charge the battery. The battery is in charging state, and the red indicator light will light up. When the battery is fully charged, the red charging indicator light will go out. After being fully charged, the circuit will automatically switch to trickle float charging state, extending the service life of the lamp.

Fault: Yellow indicator light, various states are as follows:

1. When the battery is not installed or the battery connections are not properly connected, the DC fuse is open, the battery is short circuited or fails, or the battery charging circuit is short circuited, the yellow light will flash slowly.
2. When the light source is open or short circuited, and the emergency circuit malfunctions, the yellow light will flash rapidly.
3. When the annual inspection time is less than 30 minutes, the yellow light will remain on for a long time.

Test button: Self resetting button, users should regularly check the corresponding emergency lights according to the requirements of the fire department. When the pressing time is less than 3 seconds, it simulates a main power supply failure. The lamp enters the monthly inspection state between 3-6 seconds, and when the pressing time is more than 6 seconds, the lamp enters the annual inspection state. Pressing the button during the monthly and annual inspections can restore the lamp to its normal state. Pressing continuously for more than 3 seconds in the emergency state of the lighting fixture can turn off the emergency output.

Licensed by "WAC" trademark holder - WAC LIGHTING, USA

Chinese Marketing Headquarters

: WAC Lighting (Shanghai) Co, Ltd.

: 14, Lane 299, Bi Sheng Road, Shanghai 201204, China

Address

China factory

: Manufactured WAC Lighting (Dongguan) Co, Ltd.

Address

: 390, Qingfeng Road, Qingxi Town, Dngguan, Guangdong. Postal code: 523653

Buzzer: When a lamp malfunctions, it will sound for 1 second and stop for 10 seconds, reminding users to perform maintenance according to the status of the yellow fault indicator light.

Over discharge protection: The internal circuit of the lamp has precise over discharge protection. When the battery voltage is discharged to 82% -85% of the rated voltage, the over discharge circuit will promptly cut off the discharge circuit. After cutting off, the current is zero, which can effectively protect the battery and extend the service life of the lamp.

Monthly and Annual Inspections: The lighting fixtures have automatic monthly and annual inspection functions. When in normal use and emergency operation without discharging to the automatic shutdown state, the lighting fixtures will automatically switch from the main power working state to the emergency working state every 30 ±2 days after being powered on for 48 hours and continue for 60 seconds. Then, they will automatically return to the main power working state, and the green indicator light will enter a slow flashing state. The lighting fixtures will continue to operate on the main power every year and will automatically transition from the main power working state to the emergency working state and continue until the discharge is terminated. At the same time, the green indicator light will enter a fast flashing state. If the emergency working time is less than 30 minutes, the lighting fixture buzzer will sound for 1 second, stop for 10 seconds, and the yellow indicator light will remain on.

Note:

1. Before opening the box for use, it is necessary to inspect the appearance for any damage. Before installation and use, check if the accessories are complete and read this manual carefully before starting to connect to the AC power supply for charging;
2. The main power supply of fire emergency lights should be controlled by a separate switch for fire protection, and should not be affected by the power control switch of ordinary lamps or other electrical appliances;
3. The lamp adopts a lithium battery pack, which is in an empty state and should be charged for at least 24 hours before use;
4. After each emergency, please connect the lighting fixtures to AC power as soon as possible for charging. If left unused for a long time, it will affect the battery life. It is recommended to charge and discharge them every three months;
5. Users must safely ground at the grounding mark during use;
6. Violent operation should be avoided during transportation and installation to avoid affecting the performance and protection level of the lighting fixtures. Luminaires should be avoided from being stored in high temperatures above 55 °C or low temperatures below 0 °C. When the lamp is left static without main power for more than a year, it may cause insufficient discharge time. At this time, the lamp should be fully charged and discharged three times or more to restore the normal capacity of the battery before being put into normal use.

Light source and battery:

The light source and battery of this series of lamps are non user replaceable. If necessary, please contact your local dealer or manufacturer.

Maintenance and daily maintenance:

Cotton cloth and high-purity alcohol can be used to wipe the emergency light housing. Be careful not to use water or gasoline, as it may damage the emergency light housing and other parts. Do not use in environments with rainwater, humidity greater than or equal to 95%, or corrosive environments. When necessary during the operation of the lamp, the lamp can be put into monthly and annual inspection status according to the requirements of the test button.