

## Installation statement:

1. Please read the instructions carefully before installation;
2. Ask a professional electrician to install;
3. In order to avoid the danger of electric shock, please confirm to turn off the power supply before installation and maintenance;
4. The lamp can be embedded in the installation surface of the ceiling, and sufficient installation space should be reserved. Do not cover the heat insulation and combustible materials above the lamp to avoid causing fire;
5. If the glass is cracked, please replace it immediately;
6. Do not install the lamp on the unstable and unstable skylight to avoid the lamp falling;
7. Keep the manual for reference;
8. The light source in this luminaire shall be replaced by the manufacturer or its service agent or a similarly qualified person.

## product size (unit: mm) :

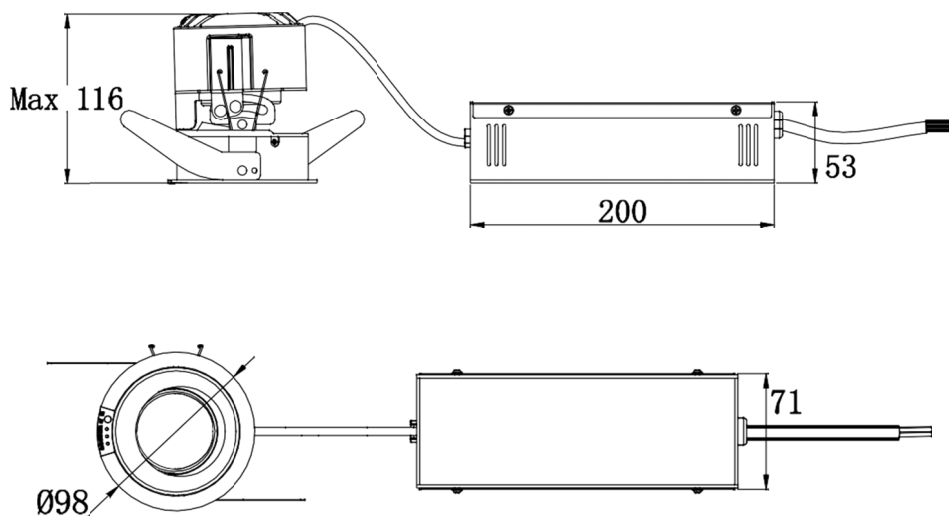

## lamp installation:

1. Take the product out of the packing box and check whether the lamp accessories are complete before installation;
2. Make sure that there is enough space on the ceiling to install the lamps (unit: mm), and ensure that the width direction can put down the electrical box;
3. Dig a  $\phi 93$ mm round hole in the ceiling;

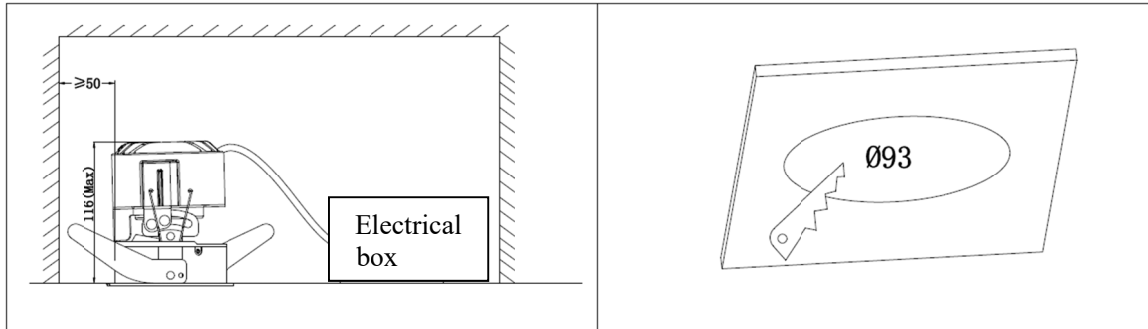

4. Connect the power input wire of the lamp to the corresponding power supply system. Brown is connected to the live wire, blue is connected to the neutral wire, black is connected to the switch wire (in the same phase as the live wire), and yellow-green is connected to the ground wire.

**Warning:** If the external cable of the lamp is damaged, it needs to be replaced by a professional to avoid dange;

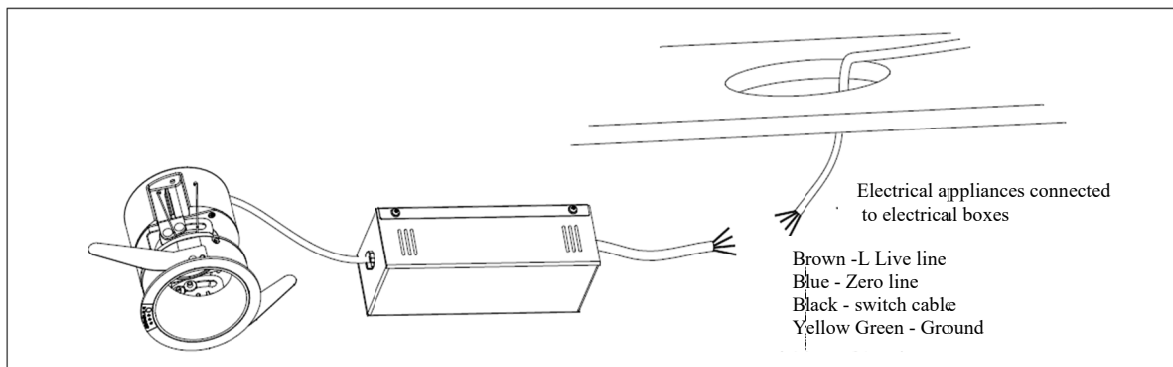

5. After the input wire of the electrical box is connected to the power cord, remove the reflector cover, send the wire and junction box to the ceiling, hold down the flanging of the lamp with both thumbs, and press the shrapnel in the direction of the lamp with the other four fingers until the shrapnel enters the ceiling hole;
6. Hold the lamp with both hands into the ceiling hole until the lamp panel is flat with the ceiling surface;
7. When the mains power AC220V is connected, the lamp is in the main power state, and then click the test button to check whether the emergency state of the test lamp is working normally ;

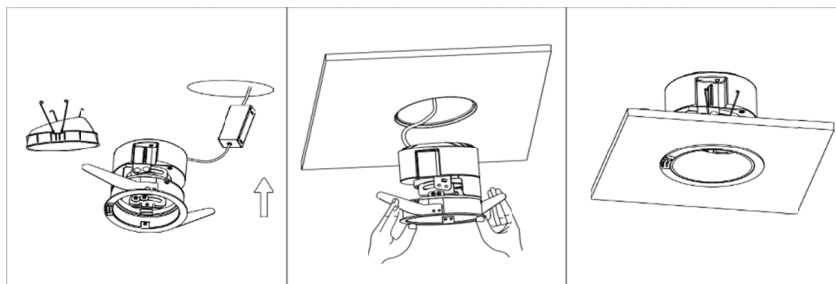

## Main Technology Parameters:

Product series: HG-ZLZD-E16WDDP31
Product name: Fire emergency lighting
Rated power supply voltage: 220V ~ 50Hz
Light source name/Parameters: LED/DC 31V-38V
Implementation standard: GB17945-2010
Emergency output luminous flux: > 50lm
Main power consumption: 16W
Enclosure protection class: IP30
Emergency working time: 90 min
Battery model and specification: Li-ion 18650 2200mAh 3.7V 8.14Wh

Product series: HG-ZLZD-E22WDDP31
Product name: Fire emergency lighting
Rated power supply voltage: 220V ~ 50Hz
Light source name/Parameters: LED/DC 31V-38V
Implementation standard: GB17945-2010
Emergency output luminous flux: > 50lm
Main power consumption: 22W
Enclosure protection class: IP30
Emergency working time: 90 min
Battery model and specification: Li-ion 18650 2200mAh 3.7V 8.14Wh

## Performance and usage instructions:

**There are:** red (charging), green (main), yellow (fault) three color indicators (or a red, yellow and green three-color indicator), test One button, one buzzer (inside the electrical box).

**Main power:** green indicator light, when the indicator light is long bright, it means that the mains power is normal (Note: the lamp has a voltage automatic conversion circuit, if the mains voltage is about 150V When, the lamp will be transferred from the main power state to the emergency state, when the mains voltage rises to about 170V, the lamp will automatically restore the main power state from the emergency state. Use this lamp Check whether the input AC voltage is normal. If this indicator blinks slowly, the lamp enters the monthly inspection state. This flash indicator indicates that the luminaire has entered the annual inspection state

**Charging:** Red indicator, when the AC input of the lamp is connected to the AC220V power supply, the circuit in the lamp automatically charges the battery, and the charging state of the battery is red When the battery is fully charged, the red charging indicator light is extinguished, and the circuit automatically switches to the trickle floating charging state after full charge, extending the service life of the lamp

**Fault:** The indicator is yellow, and the status is as follows:

1. When the battery is not installed or the battery cable is not properly connected, the DC fuse is open, the battery is short-circuiting or failing, or the battery charging circuit is short-circuiting, the yellow indicator blinks at a slow time.
2. The light source is open or short circuited, and the yellow light is blinking quickly when the emergency circuit is faulty.
3. When the annual inspection time is less than 30min, the yellow light is on for a long time.

**Test button:** self-compound button, the user should be according to the requirements of the fire department to carry out regular inspection of the emergency light. When the pressing time is < 3S, the analog main power supply is faulty.

Press the time within 3-6S to enter the monthly inspection state, press the time > 6S lamps into the annual inspection state, monthly inspection and annual inspection can be returned to normal by clicking the button. Under the emergency condition of the lamp, press > 3S continuously to turn off the emergency output.

**Buzzer:** When the lamp fails, it rings for 1S and stops for 10S, reminding the user to repair according to the status of the yellow fault indicator.

**Overdischarge protection:** the lamp circuit has accurate overdischarge protection. When the battery voltage is discharged to 82-85% of the rated voltage, the overdischarge circuit will cut off the discharge circuit in time. The current is zero after cutting off, which can effectively protect the battery and extend the service life of the lamp.

**Monthly inspection and annual inspection:** the lamp has automatic monthly inspection and annual inspection function, in normal use and in the emergency work process does not discharge to the automatic shutdown state, the lamp in After 48H power on, the working state of the main power automatically changes to the emergency working state every 30±2 days and lasts for 60 seconds, and then automatically recovers to the working state of the main power, and the green finger indicates The indicator blinks slowly. If the lamp continues to work on main power every 1 year and does not discharge to the state of automatic shutdown during emergency work, it will automatically work on main power Turn into the emergency working state and continue until the discharge terminates, and then automatically restore to the main power working state, while the green light enters the fast blinking state, if the emergency working time Within 30 minutes, the lamp buzzer will sound for 1S, stop for 10S, and the yellow indicator will keep on.

**Notes:**

1. Check the appearance for damage before unpacking. Before installation and use, check whether the accessories complete and read this manual carefully before connecting the AC power Source charging;
2. the main power supply of the fire emergency light should be controlled by a separate fire switch, not affected by the power control switch of ordinary lamps or other electrical appliances;
- 3.the lamp adopts lithium battery pack, the battery pack is in the empty state, should be charged for more than 24 hours before use;
- 4.the lamp after each emergency, please connect the AC power as soon as possible to charge, a long time when not used, will affect the battery life, it is recommended to charge and discharge every three months Once;
5. the user must be safely grounded at the grounding sign when in use;
- 6.the transportation and installation process should avoid violent operation, so as not to affect the and performance protection level of the lamp. Lamps should be avoided stored at high temperatures greater than 55 ° C or less than 0 ° C ;At low temperature, when the lamp is static placed in the state of no main power for more than one year may cause insufficient discharge time, at this time the lamp should be fully charged and discharged more than three times,To restore the normal capacity of the battery and then put into normal use.

**Light source and battery:**

The light source and battery of this series of lamps are replaced by non-users, if necessary, please contact the local dealer or manufacturer.

**Maintenance and daily maintenance:**

Use cotton cloth and high purity alcohol to wipe the emergency lamp shell. Do not use natural water and otherwise it will damage the emergency lamp shell and other parts. Please do not stand in gasoline, Use in rain, humidity greater than or equal to 95% environment, corrosive environment. When necessary during the operation of the lamp, the lamp can enter the month according to the use requirements of the test button Inspection and annual inspection status.