

## Product model:

This installation manual is applicable to LED outdoor FUEGO PRO3 embedded line lights, EIL310 \* series, EIL305 \*, EIL303 \* series, etc; Among them, "\*" includes information on different power levels, control systems, light angles, color temperatures, and appearance colors of lamps.

## Installation Precautions:

1. Please read the instruction manual carefully before installation;
2. Please hire a professional electrician for installation;
3. To avoid the risk of electric shock, please confirm to turn off the power before installation and maintenance;
4. Before installing the lighting fixtures, please confirm that the installation surface is firm and reliable to avoid loosening or falling off of the lighting fixtures;
5. Keep the instruction manual for reference only

## Installation method and steps:

1. The installation method of this line lamp is suitable for embedded and buried installation, and the lamp is clamped and fixed with the installation surface through the embedded lamp bracket.
2. Connect the male and female terminals led out from the lamp to the corresponding male and female terminal connectors: the brown line represents the positive pole of the power supply, the blue line represents the negative pole of the power supply, the red line represents the dimming positive pole, the black line represents the dimming negative pole, and the gray line represents the addressing line. This lamp uses a 24VDC power supply and the positive and negative poles cannot be reversed.

## One、Embedded installation

1. Before installing the lighting fixtures, confirm that there is sufficient space on the windowsill or floor to install the fixtures, and ensure that the X dimension thickness is less than 25mm (in millimeters). As shown in Figure 1.

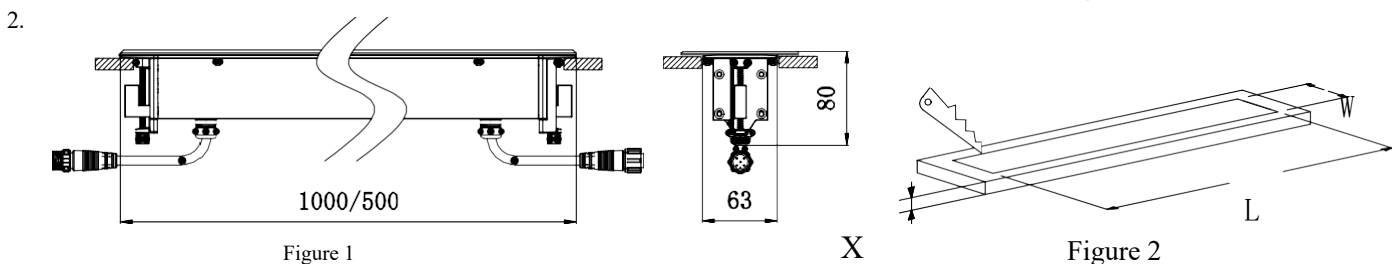

2. According to the model of the lighting fixture, grooves should be made on the windowsill or floor. The corresponding dimensions of the grooves are as follows, and the shape of the grooves is shown in Figure 2.
3. Use a Phillips screwdriver to rotate the M5 screw and rotate the embedded lamp bracket to the bottom (nut end) to ensure a certain locking force. Connect the power cord of the lamp to the already laid circuit (waterproof box can be added according to actual needs) (Figure 3). Then carefully install the lamp into the already opened hole, and then use a Phillips screwdriver to tighten the M5 screw and lock it. At this time, the line lamp bracket will move upwards and clamp the installation slot (Figure 4). Similarly, simply tighten the screw on the other end. Connect the power and the lamp can be used normally.

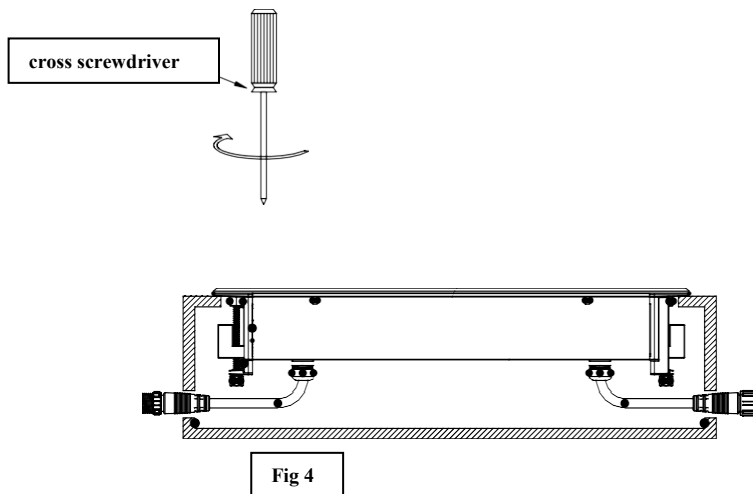
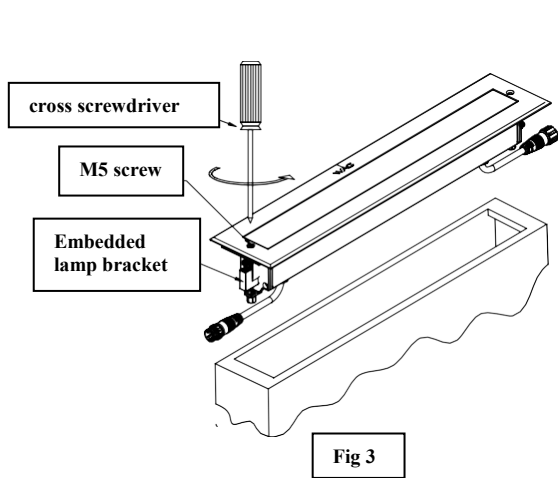

Product model	Slot size	Slot size	
		long (L/mm)	wide (W/mm)
EIL310-*		980	65
EIL305-*		480	65
EIL303-*		280	65

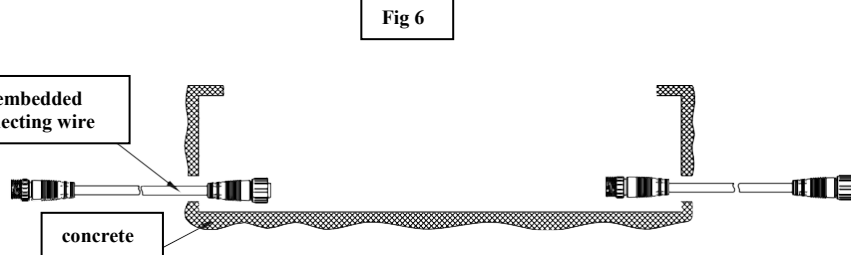
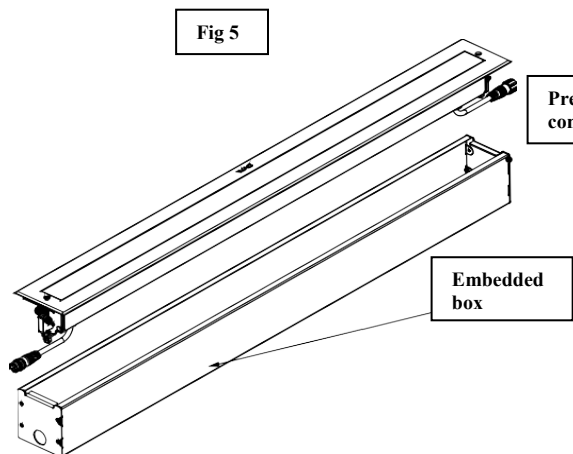

## two、Buried installation

- 1.First, dig a groove on the ground and thread the embedded connecting wire through a small hole through the embedded box. Finally, pour concrete around the embedded parts to fix them. Connect the light fixture wires to the corresponding interfaces of the embedded connecting wires (Figure 5 and Figure 6).
2. Carefully place the lamp into the embedded part, and finally use a Phillips screwdriver to rotate the M5 screw and lock it, so that the line lamp can be locked onto the embedded part (Figure 7). After the concrete solidifies, it can be used normally by connecting a 24V DC power supply.

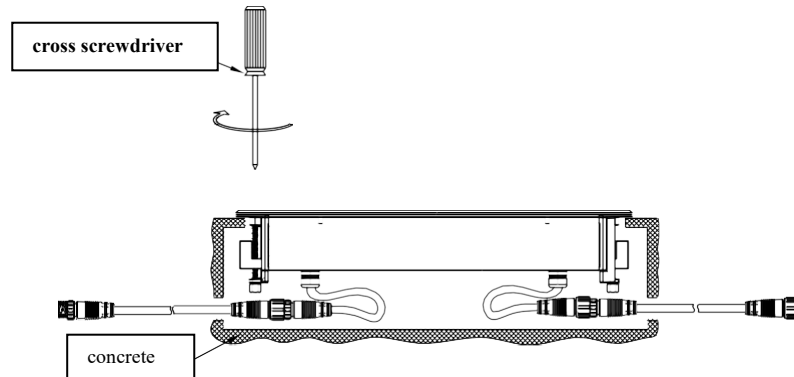
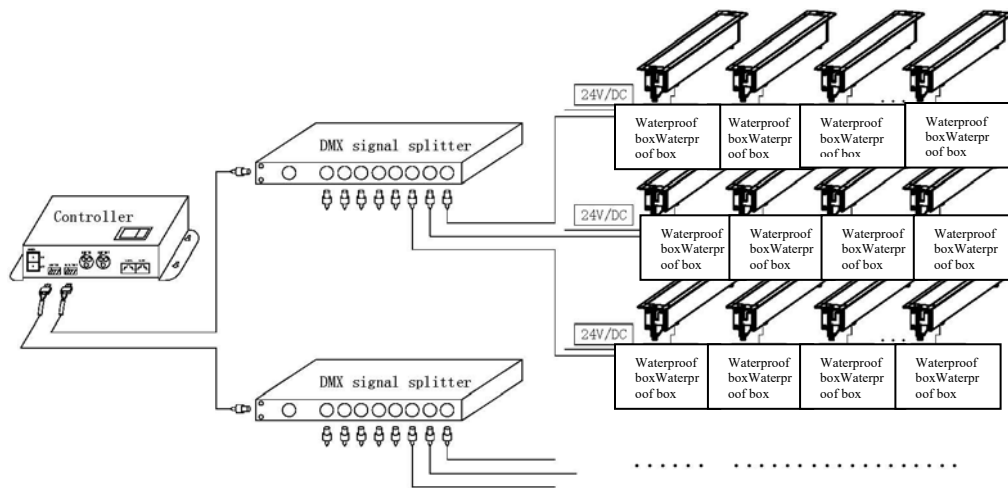

Figure 7

## Three、DMX512 Dimming Control

1. Wiring method for DMX512 dimming lamps with constant voltage 24V/DC (Figure 8).

Figure 8



### Remarks:

The wire connection must use a waterproof junction box with an IP65 or higher rating, and the waterproof joints of the junction box must match the leads of the lighting fixtures. It is recommended that the total length of the splicing of the lighting fixtures connected to each power circuit should not exceed 5 meters, and it is advisable to have no more than 32 lighting fixtures carried by each DMA signal amplifier.