

Installation Precautions:

1. Please read through the Instructions before installation.
2. The product should be installed by a professional electrician.
3. Make sure the power supply is cut off before installation and maintenance, to avoid the risk of electric shock.
4. Lighting installation is subject to local laws and regulations.
5. It is suitable for indoor and outdoor installation.
6. Keep the instruction manual for reference in case you need to use it.

Light Installation and Wiring:

Note: All installation and replacement or repair operations need to be cut off from the mains power!

The luminaire should be installed in such a way that it will not be stared at a distance of less than 3 meters for a long time.

1. Unpack the package, take out the lamp, and loosen the fastening screws on the side of the base with an Allen wrench (4.0mm). Take out the installation chassis counterclockwise, drill $\text{Ø}12$ holes on the mounting surface, the center distance of the hole is $L=100\pm 10\text{mm}$, fix the M8 expansion bolt, place the chassis, and then lock the nut with a tool (as shown in Figure 1)

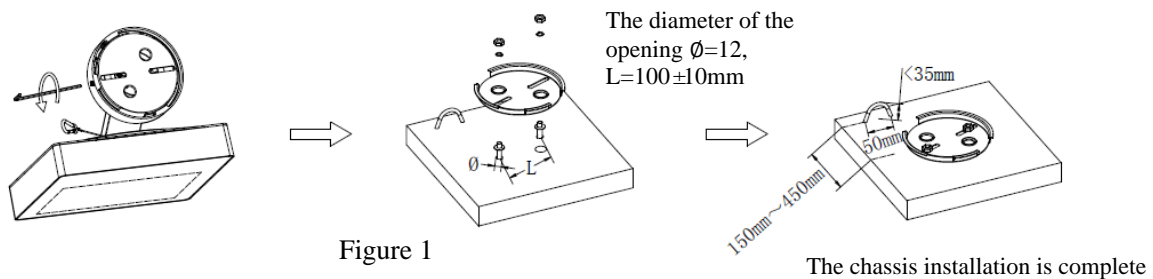

Figure 1

2. Thread the lamp cable out of the cable of the installation chassis

Adjust the base and install the chassis notch, the two are coordinated, and the base is screwed clockwise. Then use an Allen wrench (4.0mm) to lock the side fastening screw (as shown in Figure 2);

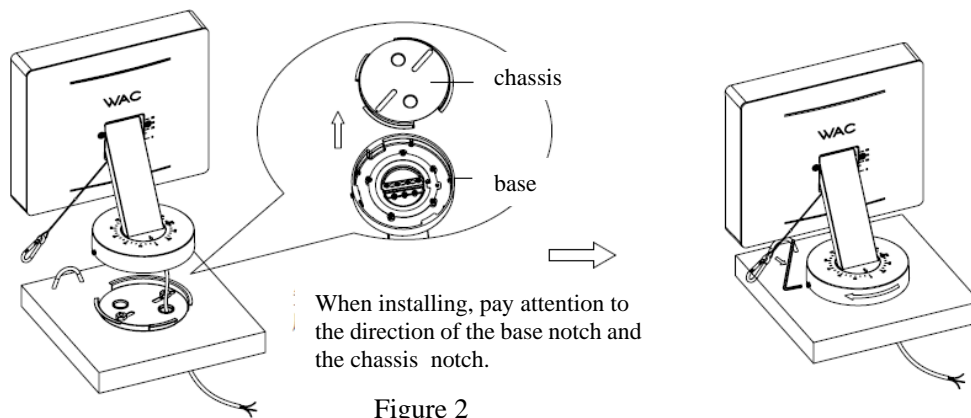
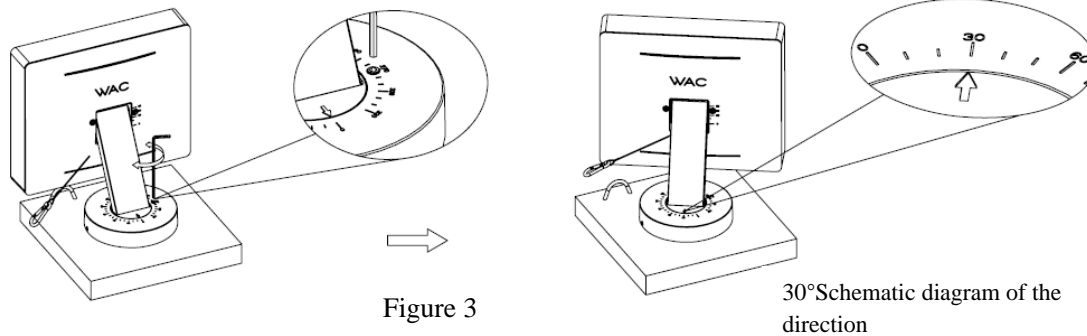
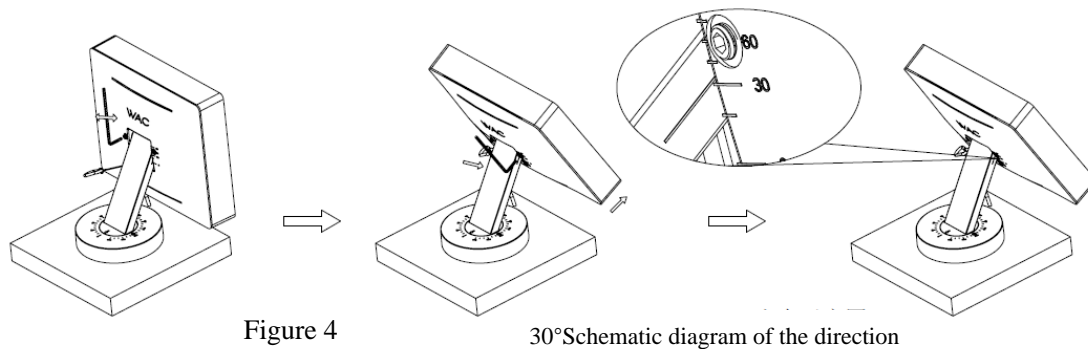

Figure 2

3. Adjust the horizontal direction of the lamp $0\text{-}330^\circ$ (clockwise), rotate the corresponding Angle horizontally, align the arrow with the silk screen scale line of the base, lock the screws on the base (tool 4.0mm hex key) clockwise, and release the adjustment in the reverse direction (Figure 3);



4. Vertical adjustment of the lamp from 0° to 90° (counterclockwise), The corresponding angle of the rotating lamp body is aligned with the scale mark of the lamp body support arm, the fastening screw (tool 4.0mm hex wrench) on the lamp body is locked in a clockwise direction, release the adjustment in the opposite direction (as shown in Figure 4);



5. Connect the power cord of the lamp with the waterproof junction box for the mains (the lamp does not include the junction box). Then the steel cable buckle is fixed, and the installation of the lamp is completed (as shown in Figure 5).

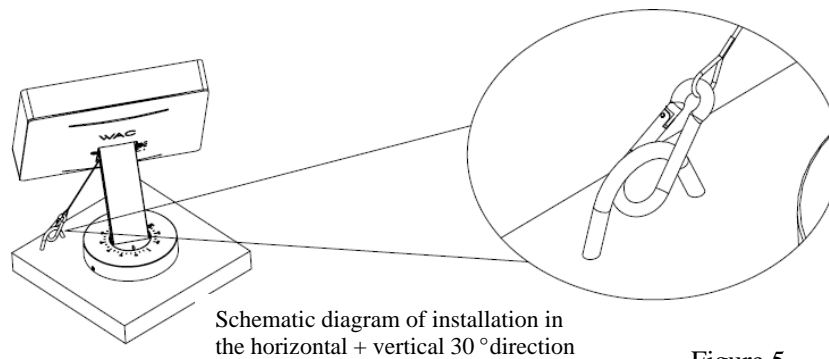

Replacement and repair of lamps and lanterns:

You need to turn off the power first and wait for the lamp to cool down enough before operating. The disassembly process is reversed from the installation sequence, and the replacement or repair process is carried out by professionals.

Indicate: 1. The cable is not included, and a waterproof 3-core cable is used, The cable diameter is Ø5-Ø9mm, (Identification on the connector: FireWire L; Neutral line N; ground );

2. Input: 220-240V ~ 50/60Hz.

Precautions: 1. If the glass shield is found to be damaged during installation, it must be replaced;

2. When the glass shield is damaged and replaced, the customer can only use the glass protection provided by the company.