

Installation Precautions:

1. Please read through the Instructions before installation.
2. The product should be installed by a professional electrician.
3. Make sure the power supply is cut off before installation and maintenance, to avoid the risk of electric shock.
4. The installation of lighting fixtures must comply with the corresponding local laws and regulations;
5. Suitable for indoor and outdoor installation and use;
6. Keep the instruction manual for reference only.

Light Installation and Wiring:

1、Light Installation

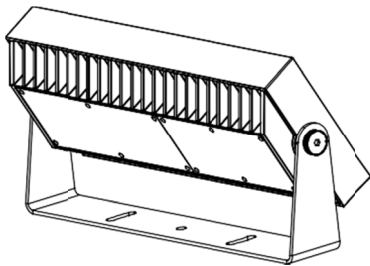

1. Use appropriate screws to install and fix the lamp through the mounting holes on the bracket

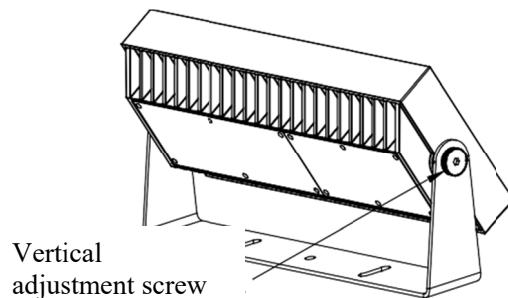

2. The internal hexagonal wrench can be used to adjust the vertical direction of the lamp for the first 30 days
Rotate 90 degrees to adjust the direction (hex wrench not included)

2、Wiring:

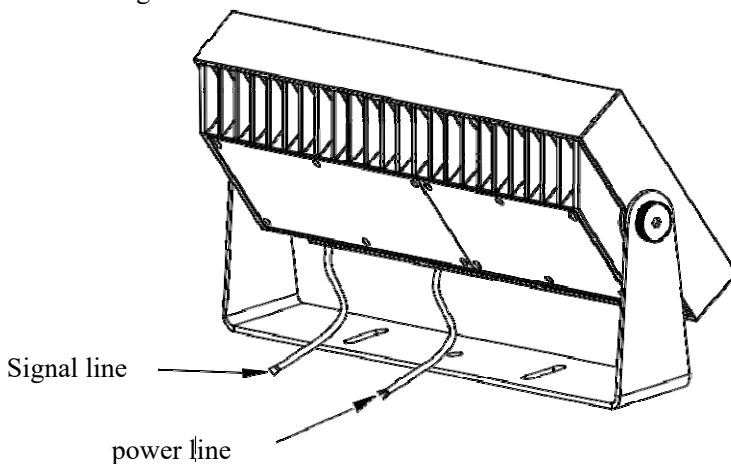

3. Match and connect each core wire of the lamp to the power input (220V/AC), and the monochrome non dimming version does not have a signal wire.

Notes

1. Cable not included, waterproof 3-core cable with a diameter of $\phi 5$ - $\phi 9$ mm (markings on the connector: live wire L, neutral wire N, ground wire);
2. If damage is found to the glass protective cover during installation, it must be replaced;
3. When the glass protective cover is damaged and replaced, customers can only use the glass protective cover provided by our company.