

Model:

1. This installation manual applies to the outdoor hard strip lights ELV103-07 series, ELV106-14 series, ELV109-21 series, ELV112-28 series.

Installation Precautions:

1. Please read through the Instructions before installation.
2. The product should be installed by a professional electrician.
3. Make sure the power supply is cut off before installation and maintenance, to avoid the risk of electric shock.
4. Before installing the lighting fixtures, please confirm that the installation surface is firm and reliable to prevent the fixtures from falling
5. Please keep this Instruction properly for future reference.

Light Installation and Wiring:

1. The installation method of this line lamp is vertical installation, with the arrow direction facing downwards. The lamp is fixed to the installation surface through stainless steel brackets at both ends, as shown in Figures 1 and 2 (Figure 1 shows the side payment method of the lamp, and Figure 2 shows the bottom payment method of the lamp).
2. Power cord led out from the lamp: The constant current lamp and the constant voltage 24V/DC ON-OFF lamp are 2-core wires - the brown wire represents the positive input of the power supply, and the blue wire represents the negative input of the power supply; The constant voltage 24V/DC DMX512 dimming lamp is a 4-core wire - the brown wire represents the positive power input, the blue wire represents the negative power input, the black wire represents the positive signal input of the DMA, and the yellow green wire represents the negative signal input of the DMA; The power cord is connected to the power supply through a junction box, and the input end of the power supply is connected to 220/50HZ AC power, as shown in Figures 1 and 3.

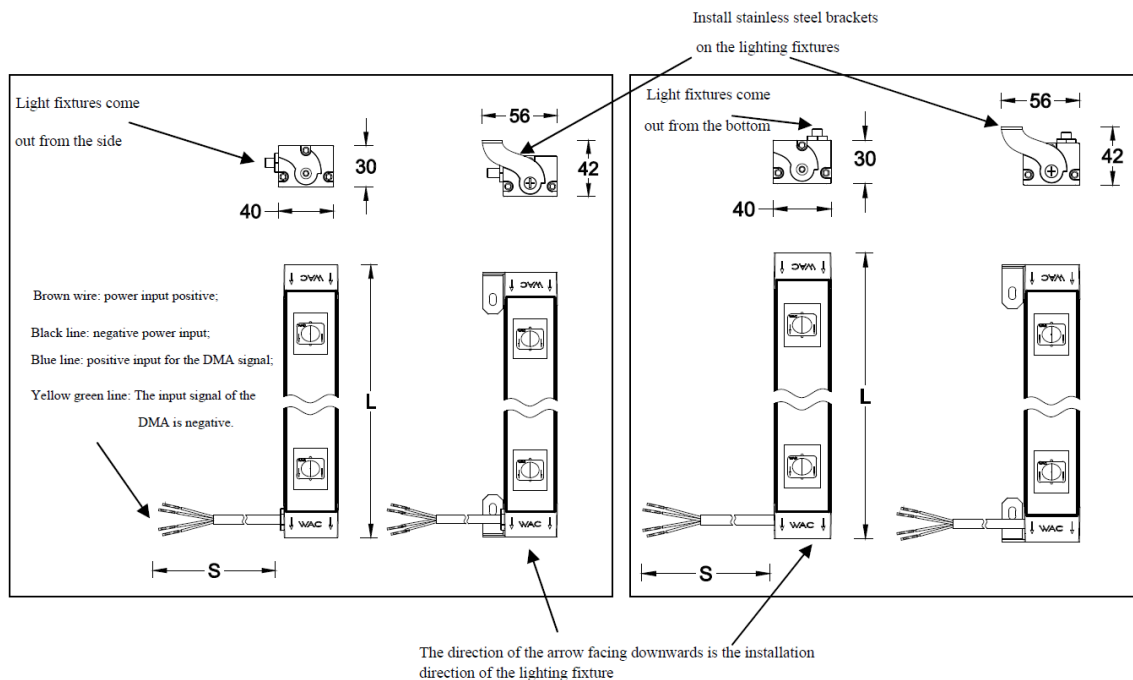

Fig.1

Fig.2

Notes:

The line diagram dimensions of the direct view vertical outdoor line light are: (width) 40 * (height) 30 * (length) (L: 1200mm/900mm/600mm/300mm). Power cord length (S: 1500mm/2000mm)

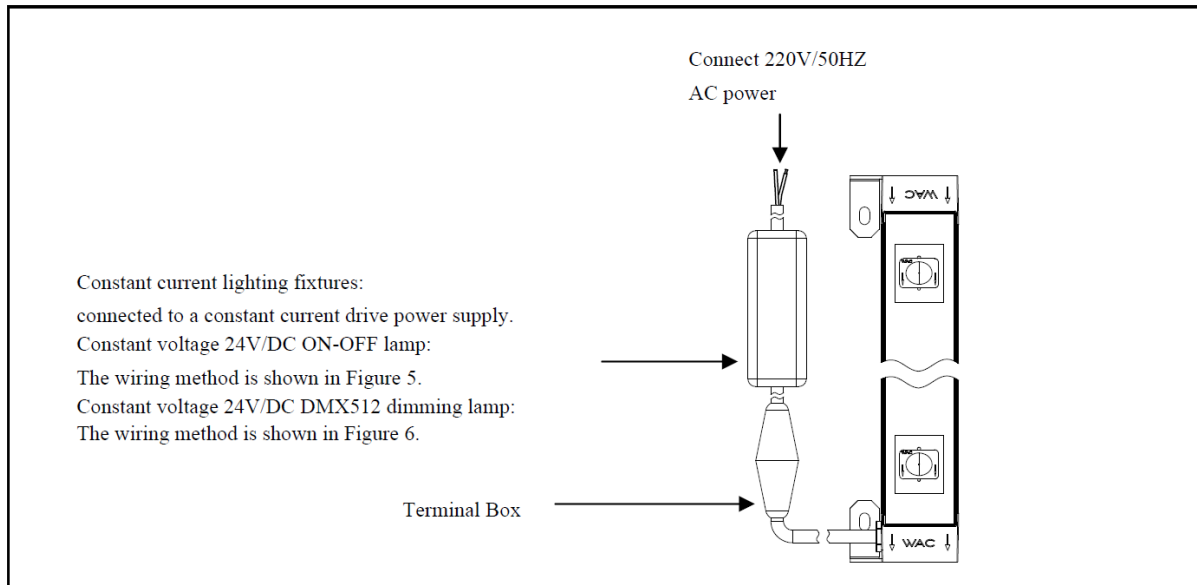

Fig.3

- When installing lighting fixtures, the end caps of two adjacent lighting fixtures need to be installed closely together, as shown in Figure 4.

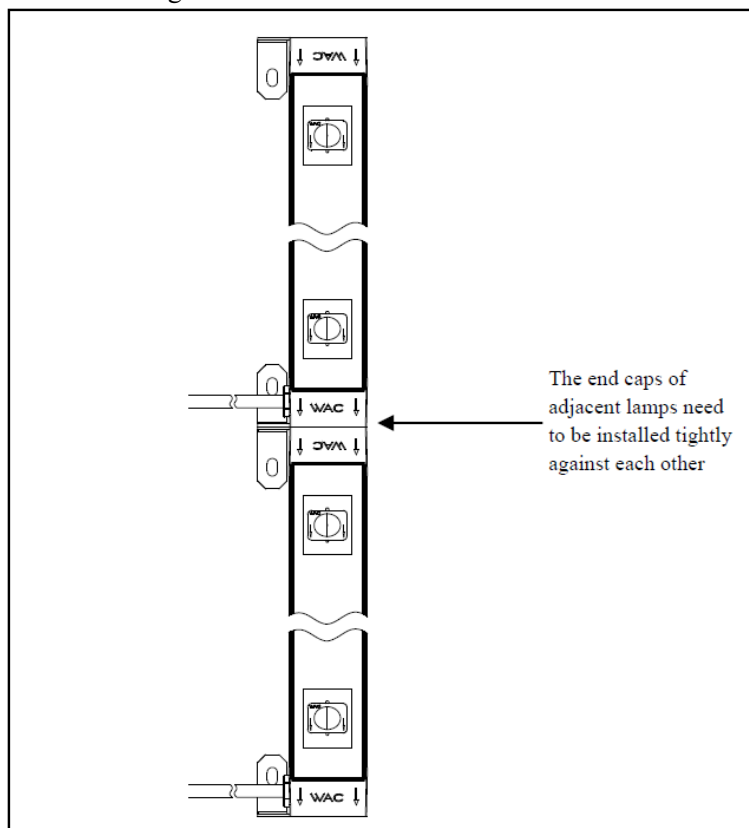

Fig.4

4. Wiring method for constant voltage 24V/DC OF-OFF lamps

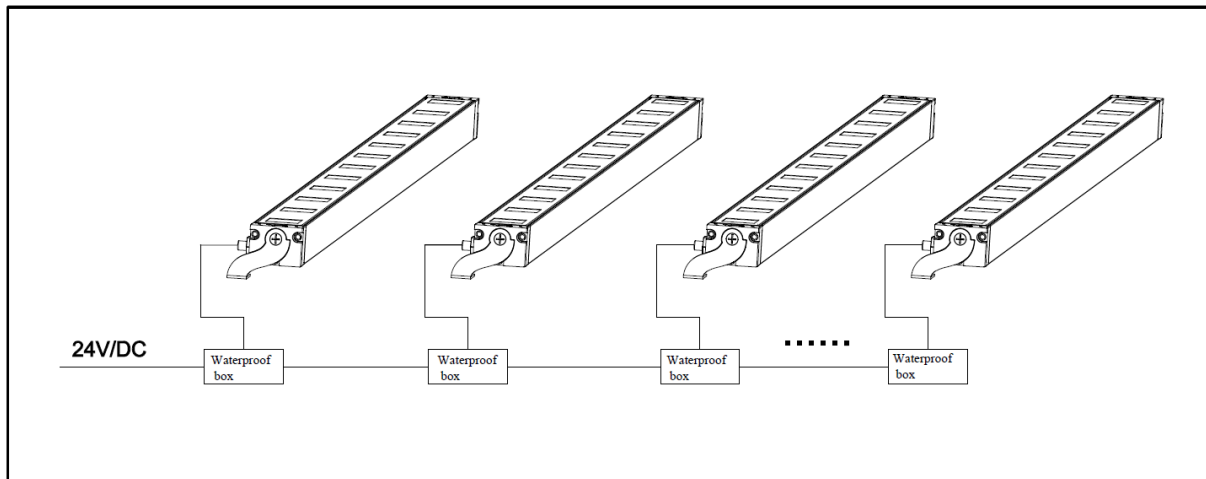

Fig.5

Notes:

Wire connections must use waterproof junction boxes of IP65 or above, and the waterproof joints of the junction boxes must match the leads of the lighting fixtures; It is recommended that the number of lamps connected to each power circuit should not exceed 25.

5. Wiring method for constant voltage 24V/DC DMX512 dimming lamps.

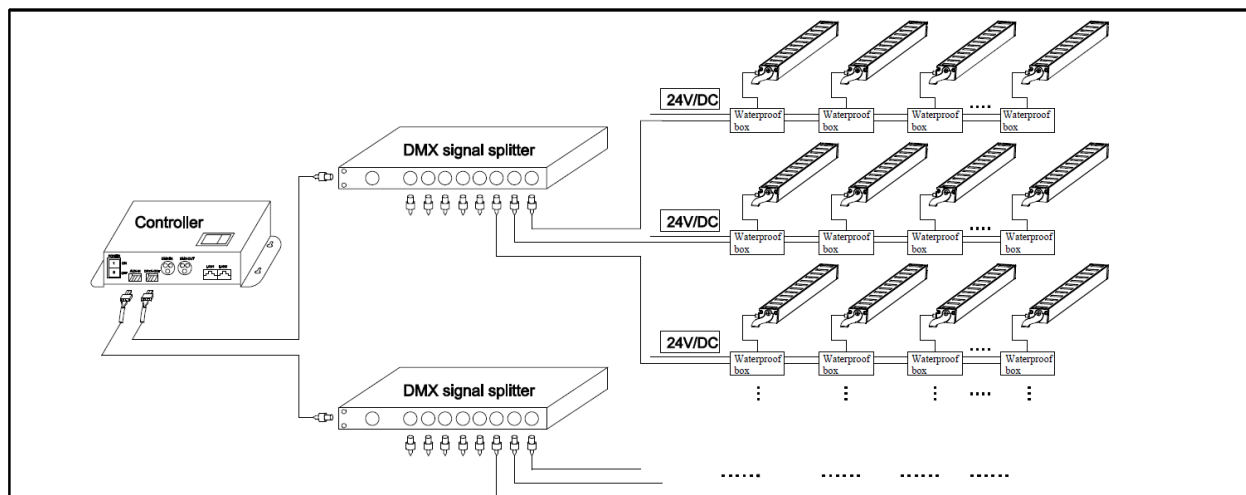

Fig.6

Notes:

Wire connections must use waterproof junction boxes of IP65 or above, and the waterproof joints of the junction boxes must match the leads of the lighting fixtures. It is recommended that the number of lighting fixtures connected to each power circuit should not exceed 25, and the number of lighting fixtures carried by each DMA signal amplifier should not exceed 170.