

Model:

This installation manual is applicable to the ELF303- * series, ELF305- * series, and ELF310- * series of LED outdoor hard strip lights, where "*" includes information on different powers, control systems, light angles, color temperatures, and appearance colors of the lighting fixtures.

Installation Precautions:

1. Please read the instruction manual carefully before installation;
2. Please hire a professional electrician for installation;
3. To avoid the risk of electric shock, please confirm to turn off the power before installation and maintenance;
4. Before installing the lighting fixtures, please confirm that the installation surface is firm and reliable to prevent the fixtures from falling;
5. Keep the instruction manual for reference only.

Installation method and steps:

1. Rotate and fix the U-shaped stainless steel bracket to a certain angle, and install two brackets (ELF303 single bracket) for ELF310 and ELF305 series lamps. The fixing hole distance of the bracket is shown in Figure 1 (self tapping screws and plastic gecko to be provided by the construction party);
2. Drill holes according to the position of the U-shaped stainless steel bracket, install plastic geckos, and lock the bracket with self tapping screws;
3. To install adjacent light strips, it is necessary to first connect the wires, drill holes, install plastic geckos, and then fix the lamps. The power cord of the lamps is distinguished by the direction of the input and output terminals. Please follow the instructions on the label on the wire for wiring, as shown in Fig 5.

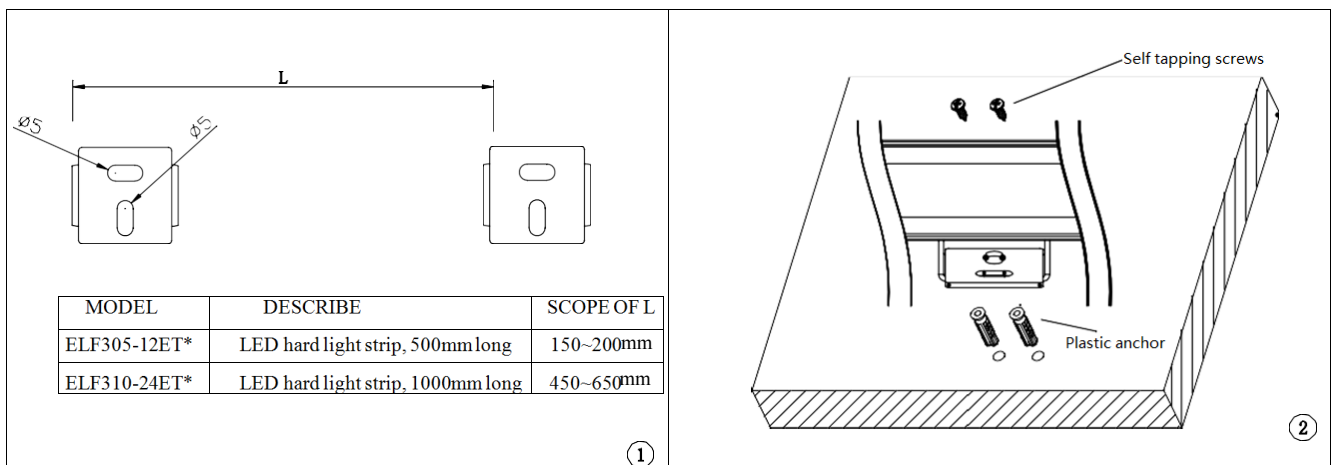

Licensed by "WAC" trademark holder - WAC LIGHTING, USA

Chinese Marketing Headquarters : WAC Lighting (Shanghai) Co, Ltd.
 Address : 14, L ne 299, Bi Sheng Road, Shanghai 201204, China
 China factory : Manufactured WAC Lighting (Dongguan) Co, Ltd.
 Address : 390, Qingfeng Road, Qingxi Town, Dngguan, Guangdong. Postal code:

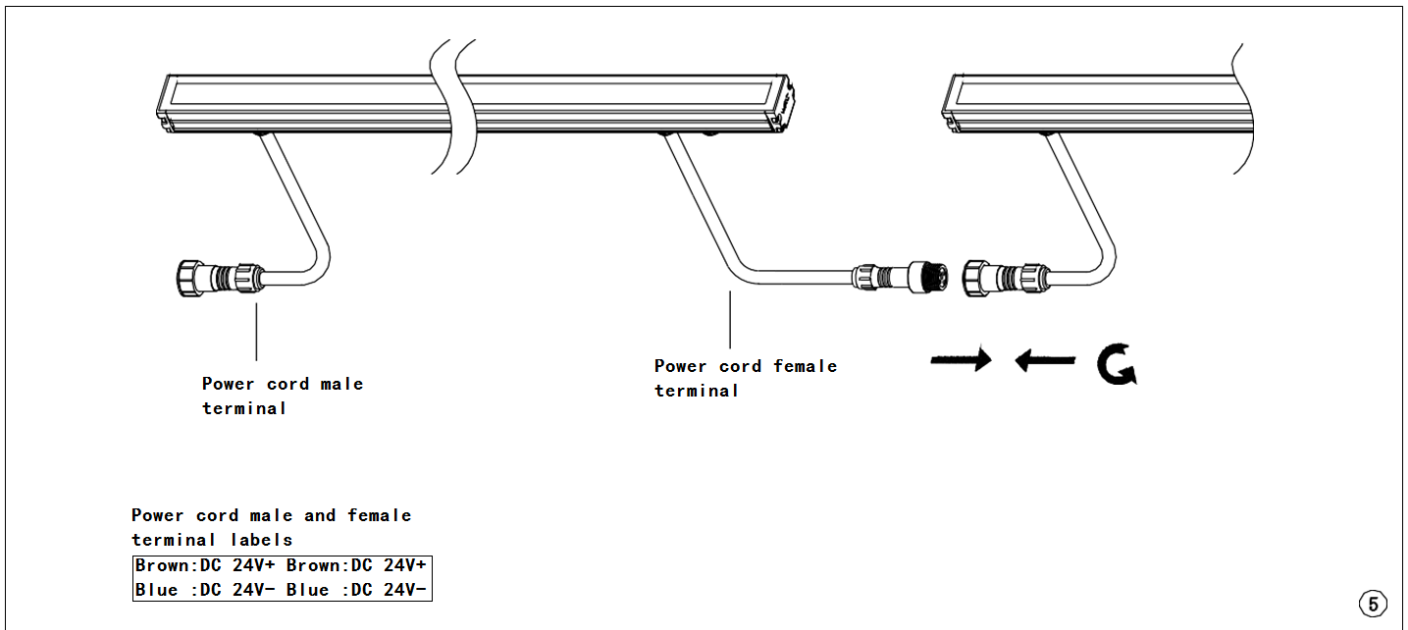
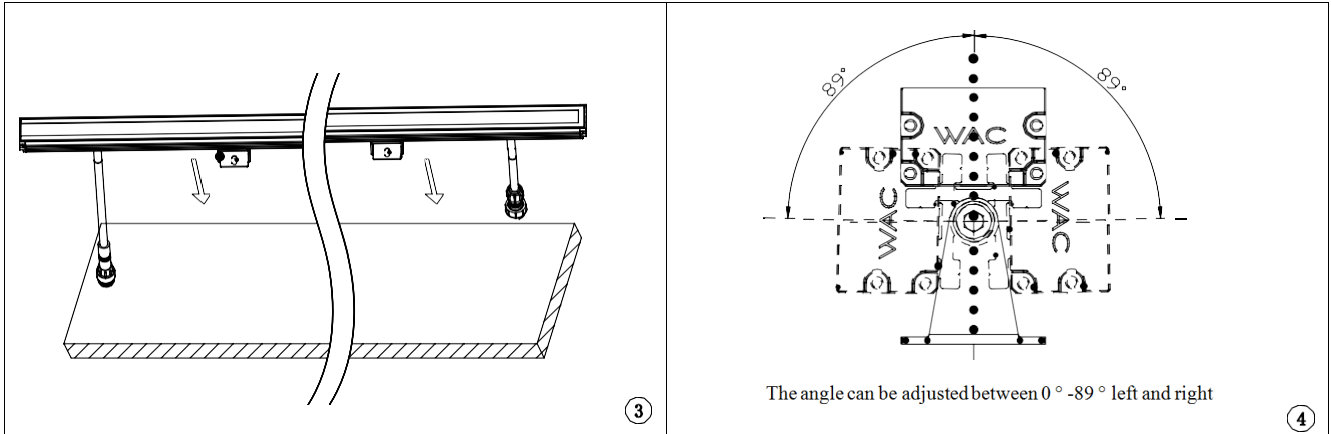

Licensed by "WAC" trademark holder - WAC LIGHTING, USA

Chinese Marketing Headquarters : WAC Lighting (Shanghai) Co, Ltd.
 Address : 14, Lane 299, Bi Sheng Road, Shanghai 201204, China
 China factory : Manufactured WAC Lighting (Dongguan) Co, Ltd.
 Address : 390, Qingfeng Road, Qingxi Town, Dngguan, Guangdong. Postal code:

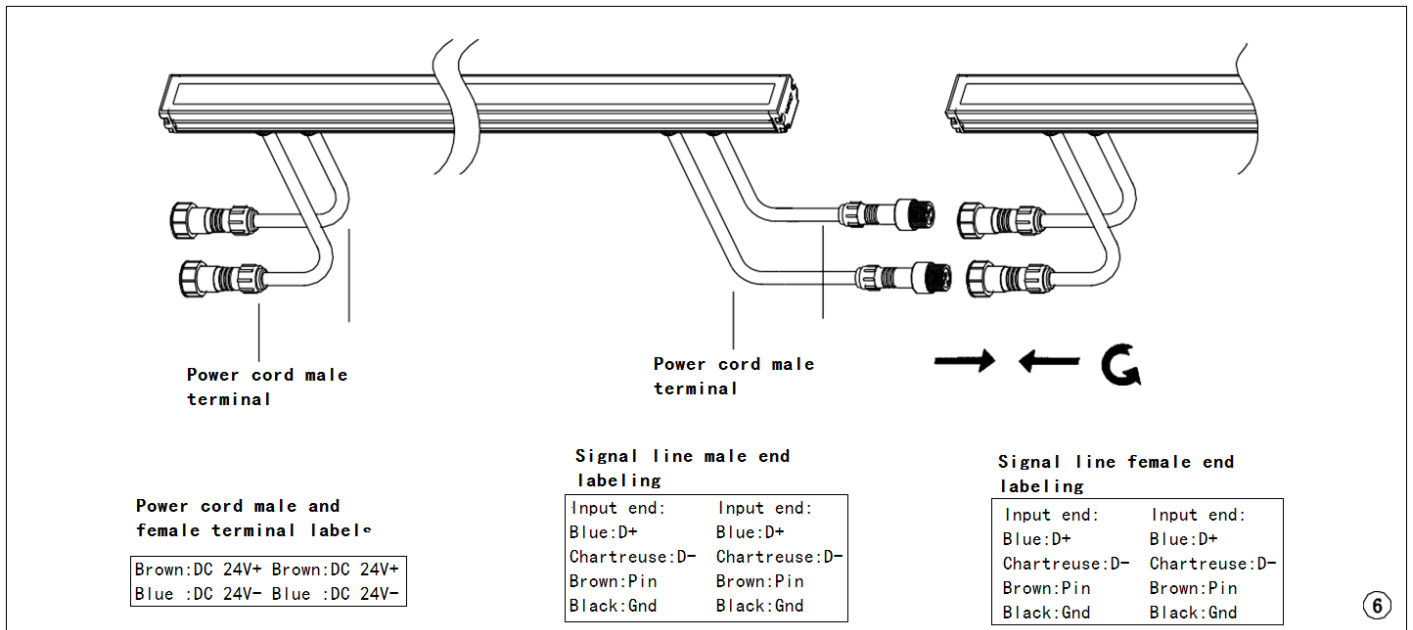

4、Refer to the schematic diagram below for wiring of the lighting fixtures

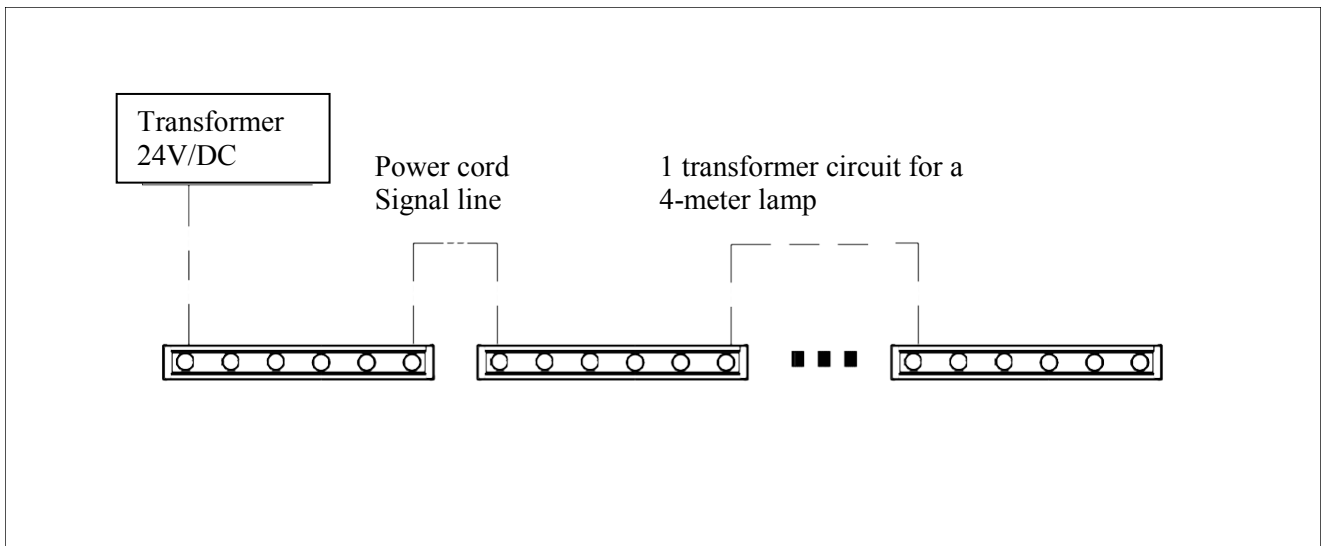

Remarks:

The connection of the power cord should use the waterproof connector wire provided by our company. It is recommended to use a transformer power circuit for 4-6 meter lamps.

5、Wiring method for constant voltage 24V/DC DMX512 dimming lamps

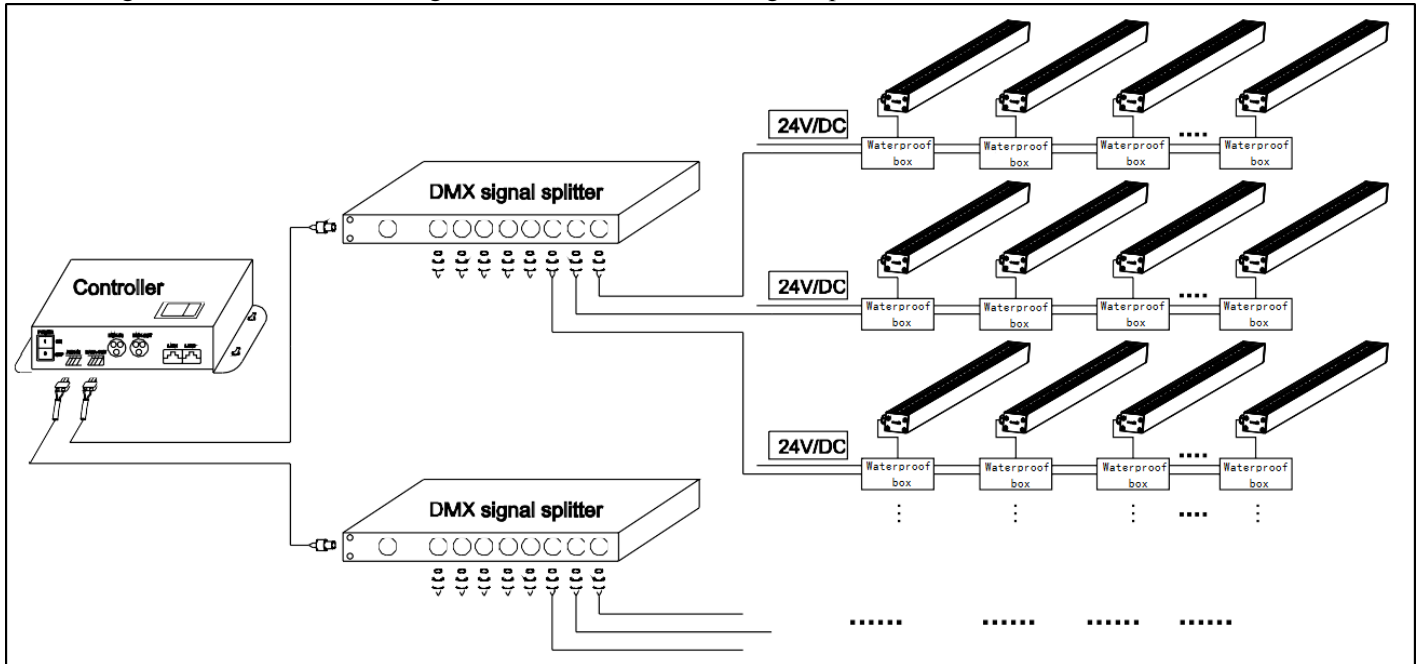

Note: The wire connection must use a waterproof junction box with an IP65 or higher rating, and the waterproof joints of the junction box must match the leads of the lighting fixtures. It is recommended that the total length of the splicing of the lighting fixtures connected to each power circuit should not exceed 5 meters, and it is advisable to have no more than 32 lighting fixtures carried by each DMA signal amplifier.

Licensed by "WAC" trademark holder - WAC LIGHTING, USA

Chinese Marketing Headquarters : WAC Lighting (Shanghai) Co, Ltd.
Address : 14, L ne 299, Bi Sheng Road, Shanghai 201204, China
China factory : Manufactured WAC Lighting (Dongguan) Co, Ltd.
Address : 390, Qingfeng Road, Qingxi Town, Dngguan, Guangdong. Postal code: