

Product model:

This installation manual is applicable to the ELC703- * series, ELC705- * series, and ELC710- * series of LED outdoor hard strip lights, where "*" includes information on different powers, control systems, light angles, color temperatures, and appearance colors of the lighting fixtures.

Installation Precautions:

1. Please read through the Instructions before installation.
2. The product should be installed by a professional electrician.
3. Make sure the power supply is cut off before installation and maintenance, to avoid the risk of electric shock.
4. Before installing the lighting fixtures, please confirm that the installation surface is firm and reliable to prevent the fixtures from falling.
5. Please keep this Instruction properly for future reference.

Installation method and steps:

1. Select the installation location of the lighting fixture, drill holes according to the position of the stainless steel bracket, install plastic geckos, and lock the installation bracket with self tapping screws; (The bracket needs to be purchased separately) There are two options for the bracket, one is adjustable and the other is not adjustable.
2. ELC705 and ELC710 series lamps have two installation brackets (ELC703 single bracket), and the fixing hole distance of the bracket refers to Figure 1 (self tapping screws and plastic gecko provided by the construction party) .
3. Insert the lamp into the installation bracket (refer to Figure 3), and if the lamp needs to be spliced (refer to Figure 4) .
4. The power cord of the lighting fixture is distinguished by the direction of the input and output terminals. Please wire according to the instructions on the label on the wire (as shown in Figure 5) .

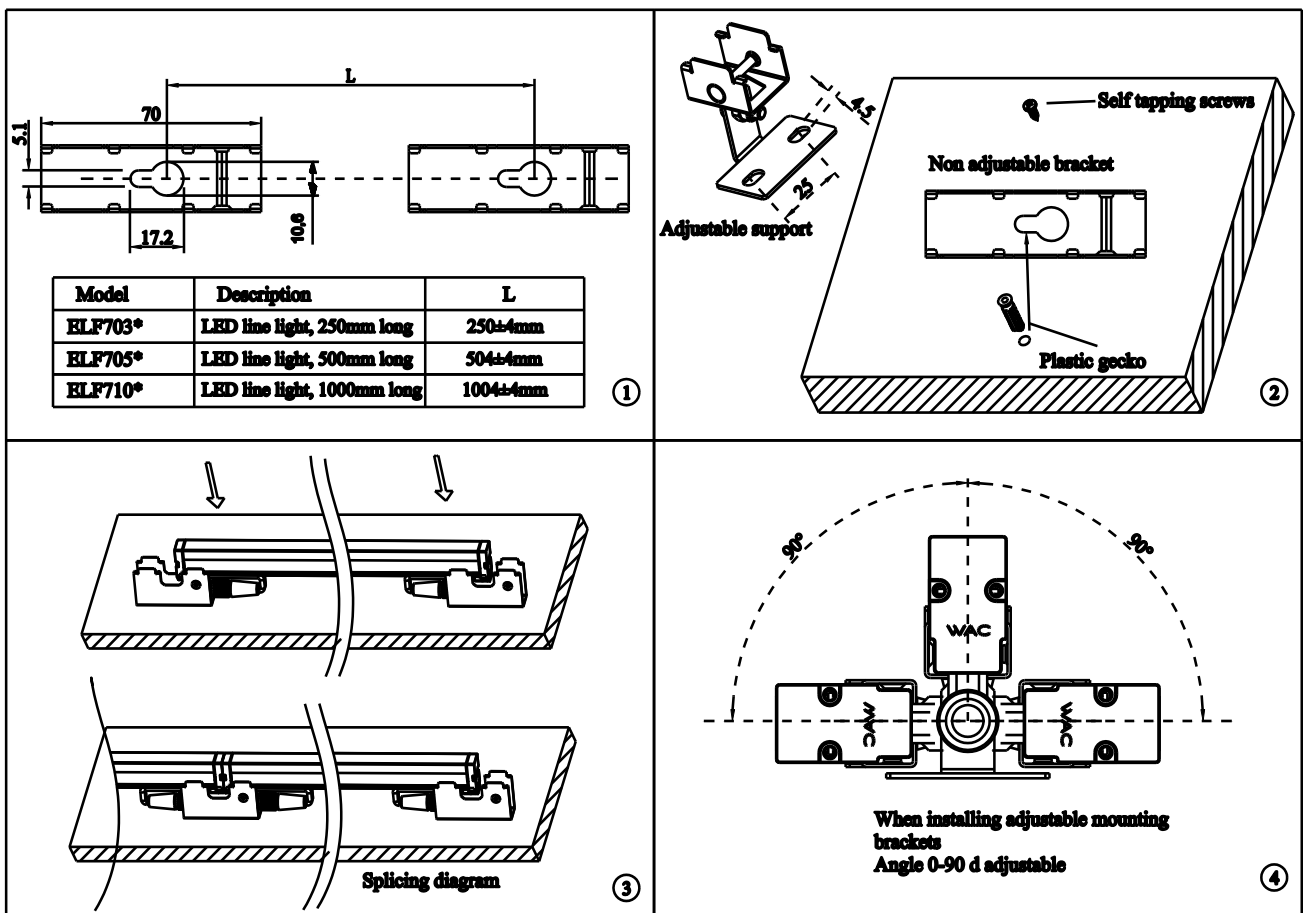

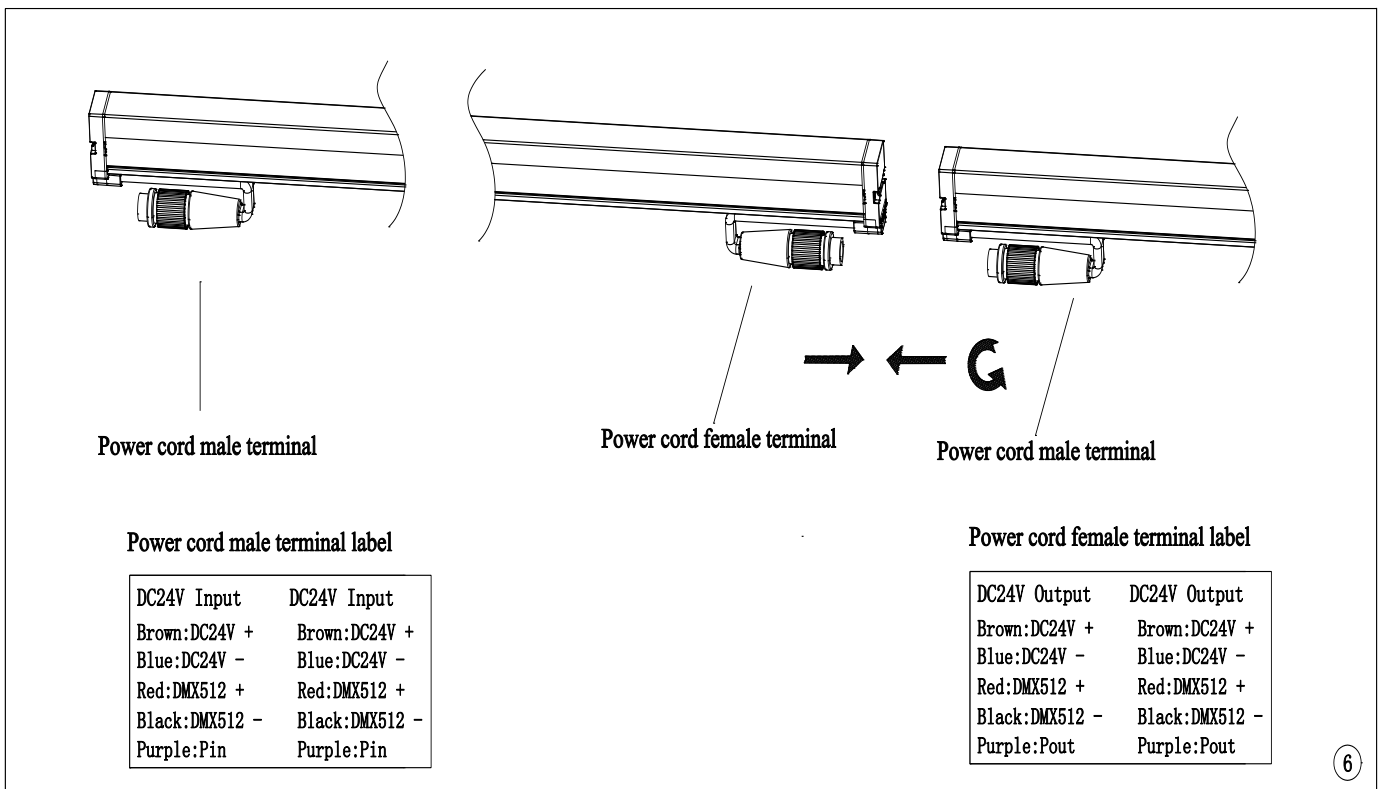
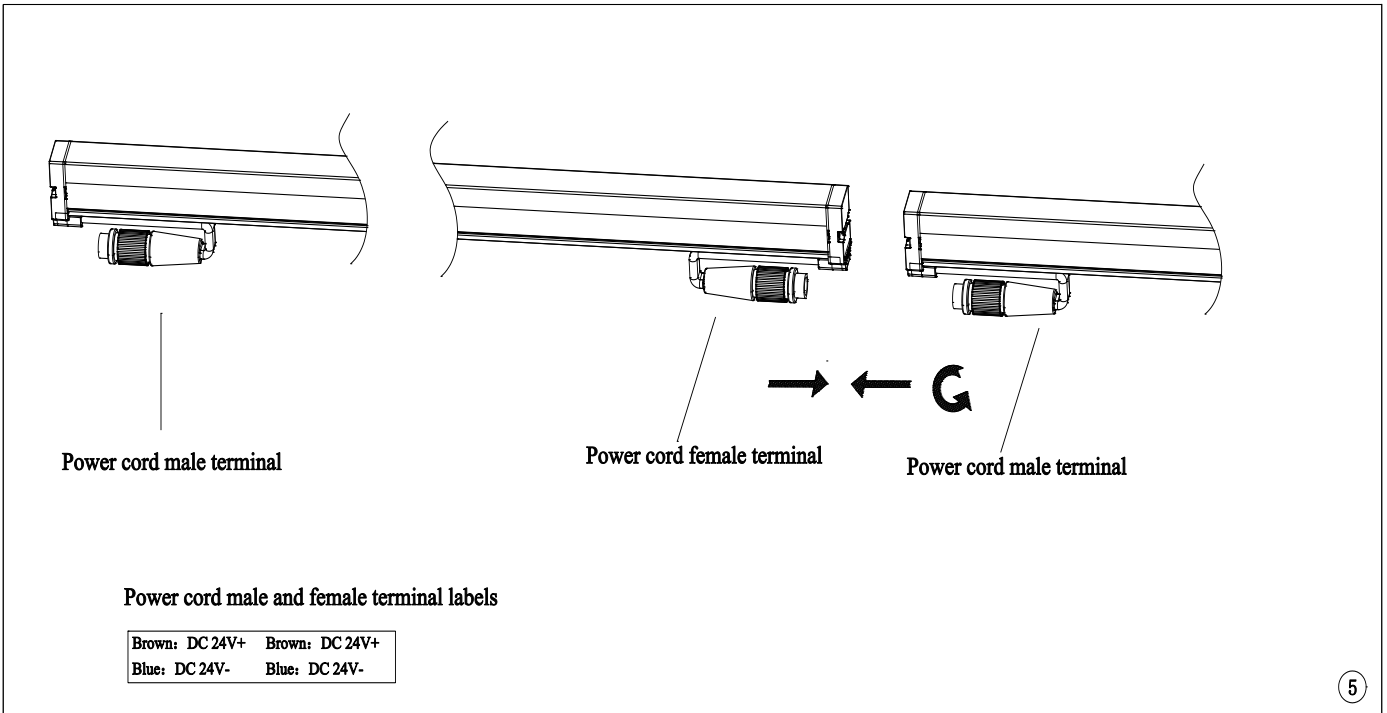

Licensed by "WAC" trademark holder - WAC LIGHTING, USA

Chinese Marketing Headquarters : WAC Lighting (Shanghai) Co, Ltd.
 Address : 14,Lane 299, Bi Sheng Road, Shanghai 201204,China
 China factory : Manufactured WAC Lighting (Dongguan) Co, Ltd.
 Address : 390, Qingfeng Road, Qingxi Town, Dngguan, Guangdong. Postal code: 523653

Refer to the schematic diagram below for wiring of the lighting fixtures:

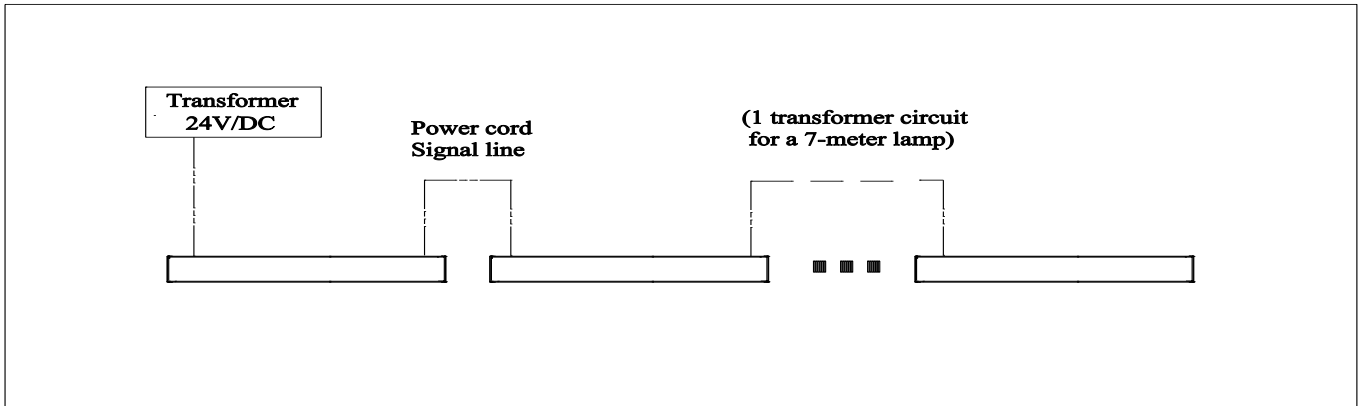

Notes:

The connection of the power cord should be made using the waterproof connector wire provided by our company. It is recommended to use a transformer power circuit for a 7-meter lamp, and the current should not exceed 8A.

Wiring method for constant voltage 24V/DC DMX512 dimming lamps:

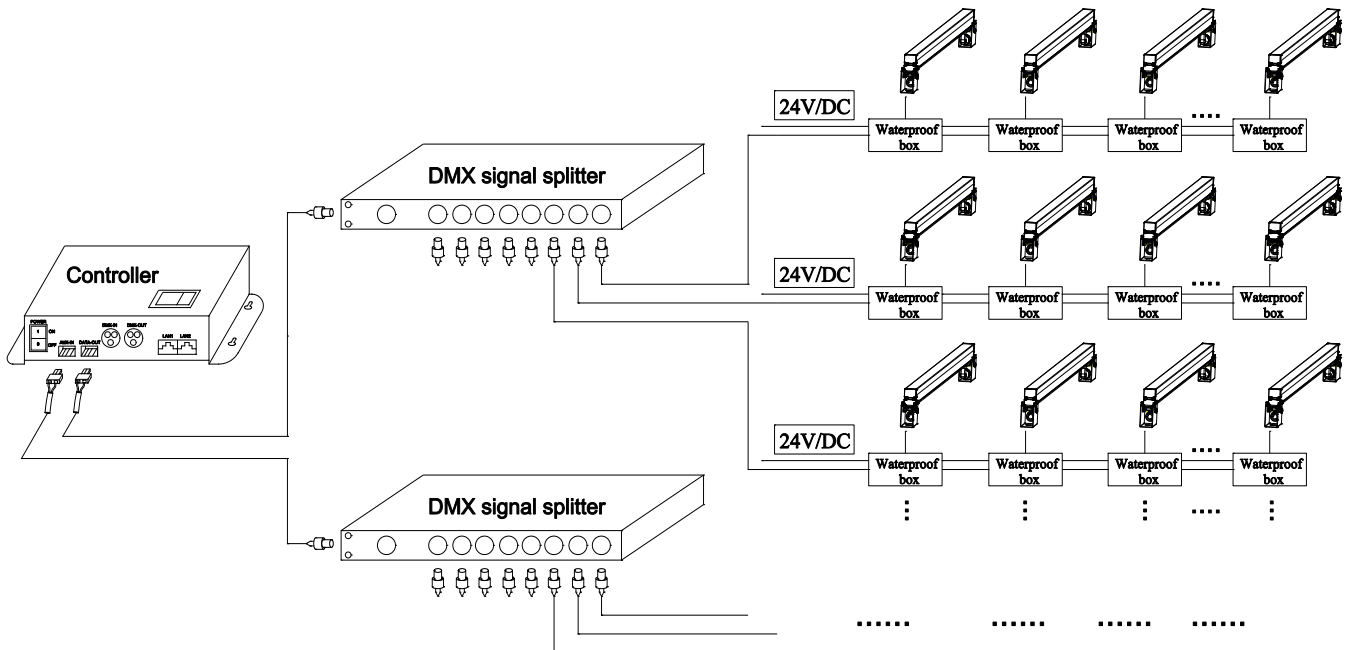

Notes: The wire connection must use a waterproof junction box with an IP65 or higher rating. The waterproof joints of the junction box must match the leads of the lighting fixtures. It is recommended that the total length of the splicing of the lighting fixtures connected to each power circuit should not exceed 14 meters, and it is recommended that each DMA signal amplifier carry no more than 32 lighting fixtures.

Licensed by "WAC" trademark holder - WAC LIGHTING, USA

Chinese Marketing Headquarters : WAC Lighting (Shanghai) Co, Ltd.
 Address : 14,Lane 299, Bi Sheng Road, Shanghai 201204,China
 China factory : Manufactured WAC Lighting (Dongguan) Co, Ltd.
 Address : 390, Qingfeng Road, Qingxi Town, Dngguan, Guangdong. Postal code: 523653